

Digital Program Controller

REX-P250 SERIES

INSTRUCTION MANUAL

IM250P01-E1

Notes:

Make sure that this Instruction Manual is always readily available to personnel who use the REX-P250 series. The contents of the Instruction Manual are subject to change without notice. If you have any questions regarding the manual, contact one of our sales people, your nearest RKC sales office, or the place where you have purchased this controller.
 * See the "Instruction Manual for Communication" for details of the communication.

Contents

1. MODEL NO.	1	6. SET DATA EXAMPLE	8
2. FUNCTIONAL DESCRIPTION	2	6-1 Program pattern setting method	8
3. FUNDAMENTALS OF DATA SETTING	3	6-2 Pattern linking method	8
4. OPERATION MODE STATUS TRANSITION	4	6-3 Fixed set-point control setting method	8
4-1 Setting in RUN program operation mode	4	7. PRIOR TO OPERATION	9
a) Program setting group	4	7-1 Setting in the user initial setting mode	9
b) Pattern setting group	5	7-2 Opening adjustment (For the position proportioning type)	9
c) Segment setting group	5	7-3 How to use pattern card	9
d) Time signal setting group	5	8. HOW TO START PROGRAM OPERATION	10
4-2 FIX: Setting in fixed set-point control mode	6	9. DESCRIPTION OF MAIN FUNCTIONS	10, 11, 12
4-3 MAN: Setting in manual control mode	7	10. WIRING	13
5. MEMORY SETTING GROUP/COMMON SETTING GROUP	6	10-1 Rear terminals	13
5-1 PID memory No. setting group	6	10-2 Wiring example	13
5-2 Alarm memory No. setting group	6	10-3 Cautions for wiring	13
5-3 Common setting group	7	11. SPECIFICATIONS	14
		12. DIMENSIONS	15
		13. DATA ENTRY FORMAT	16

1. MODEL NO.

The REX-P250 Model No. is shown inside the controller.

Model	Description	Spec. code							
		□	□	□	□	□	□	□	□
REX-P250									
Type of control operation	PID operation PID operation with auto-tuning Position proportioning PID operation	H							
Type of alarm operation	With no alarm With 1 alarm With 2 alarms	F							
Type of input	Thermocouple input RTD input Voltage/current input *1 *1 For the contents in □, refer to the signal code table.	Y							
Type of control output	Relay contact output Voltage pulse output Current output Continuous voltage output TRIAC driving trigger output		N						
Case color	Black		S						
Analog input	Non Heater break alarm function		D						
Analog output	Non Signal level selection (Refer to the signal code table)			C					
Communication function	Non RS-232C RS-422A			R					
				□					
					M				
					V				
					R				
					E				
					G				
						B			
							N		
							2		
								N	
								□	
									1
									2

1 : 0 to 10mV	6 : 1 to 5V
2 : 0 to 100mV	7 : 0 to 20mA
3 : 0 to 1V	8 : 4 to 20mA
4 : 0 to 5V	9 : Others
5 : 0 to 10V	

2. FUNCTIONAL DESCRIPTION

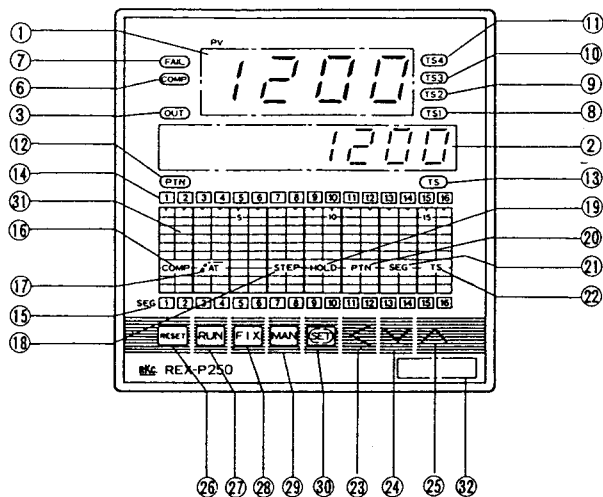

* For position proportioning type

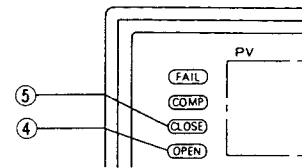

Display Unit

- ① **Measured-value (PV) display unit**
Displays measured-value (PV).
- ② **Set-value (SV)/character display unit**
Displays set-value and its characters. It can also be used as a setting display or setting digit shift key.

Indication lamps

- ③ **Control output indication lamp (OUT)**
Lights up when control output is activated.
- ④ **Open side output indication lamp (OPEN)**
Lights up when the open side control output is ON in the position proportioning type.
- ⑤ **Closed side output indication lamp (CLOSE)**
Lights up when the closed side control output is ON in the position proportioning type.
- ⑥ **Computer mode indication lamp (COMP)**
Lights up when the controller is in the computer mode (in communication with the host computer).
- ⑦ **Fail indication lamp (FAIL)**
Lights up if an error occurs in this unit.
- ⑧ **Time signal No. 1 output indication lamp (TS1)**
Lights up when time signal No. 1 output is ON. It flashes when time signal No. 1 setting is being checked.
- ⑨ **Time signal No. 2 output indication lamp (TS2)**
Functions in the same way as the time signal 1 (TS1) output indication lamp.
- ⑩ **Time signal No. 3 output indication lamp (TS3)**
Functions in the same way as the time signal 1 (TS1) output indication lamp.
- ⑪ **Time signal No. 4 output indication lamp (TS4)**
Functions in the same way as the time signal 1 (TS1) output indication lamp.
- ⑫ **Pattern mode indication lamp (PTN)**
When this lamp is lit, the 16 lamps of ⑭ act as pattern No. indication lamps.
- ⑬ **Time signal mode indication lamp (TS)**
When this lamp is lit, the 16 lamps of ⑭ act as time signal No. indication lamps.
- ⑭ **i) Pattern No. indication lamps (16)**
When the " ⑫ Pattern mode indication lamp (PTN)" lights, the activated pattern No. or setting is indicated.
- ii) Time signal No. indication lamp (16)**
When the " ⑬ Time signal mode indication lamp (TS)" lights, the activated time signal in a certain segment is indicated.
- ⑮ **Segment display lamps (SEG)**
The segment No. in program progress or that during setting lights up.

Operation keys

- ⑯ **Computer mode key (COMP)**
Pressing this key twice (within 3 sec) in succession can perform communication with Host Computer.
- ⑰ **Auto-tuning key (AT)**
Pressing this key twice (within 3 sec) in succession activates the auto-tuning function.
- ⑱ **Step key (STEP)**
Pressing this key twice (within 3 sec) in succession progresses the program by one segment.
- ⑲ **Hold key (HOLD)**
Pressing this key twice (within 3 sec) in succession stops program progress.
- ⑳ **Pattern key (PTN)**
Pattern setting group display key
- ㉑ **Segment key (SEG)**
Segment setting group display key
- ㉒ **Time signal key (TS)**
Time signal setting group display key
- ㉓ **Setting digit shift key**
Pressing this key shifts the set-value changeable digit, and also selects segment end and continuation.
- ㉔ **Set-value decrement key**
This key is used for set-value change. Pressing this key increases the set value. Pressing this key during program control quickens control time progress.
- ㉕ **Set-value increment key**
This key is used for set-value change. Pressing this key increases the set value. Pressing this key during program control fastens control time progress.

Operation keys + Indication lamps

- ⑳ **Reset key and lamp (RESET)**
Pressing this key twice (within 3 sec) in succession sets the controller to the reset mode and simultaneously lights the lamp.
- ㉑ **Run key and lamp (RUN)**
Pressing this key twice (within 3 sec) in succession sets the controller to the program control mode and simultaneously lights the lamp.
- ㉒ **Fix key and lamp (FIX)**
Pressing this key twice (within 3 sec) in succession sets the controller to the fixed set-point control mode and simultaneously lights the lamp. Pressing this key simultaneously with the SET key displays the fixed set-point control setting group.
- ㉓ **Manual key and lamp (MAN)**
Pressing this key twice (within 3 sec) in succession sets the controller to the manual control mode and simultaneously lights the lamp. Pressing this key simultaneously with the SET key displays the manual control setting group.
- ㉔ **Set key and lamp (SET)**
Pressing this key sets and also confirms various parameters. The lamp lights under the settable status and is extinguished under the setting locked status.

Others

- ㉑ **Pattern card**
Enter the pattern stored in the unit (for 1 pattern) into this card.
- ㉒ **Input range indication**
Input type and range are indicated.

3. FUNDAMENTALS OF DATA SETTING

The following shows basic data setting examples. Because parameter data is set and changed in accordance with this procedure, first carry out operations as shown in the examples to master data setting. Also, the measured-value (PV) display unit always displays a measured-value regardless of the setting.

As an example, change the level set-value in the segment setting group from 0°C to 200°C.

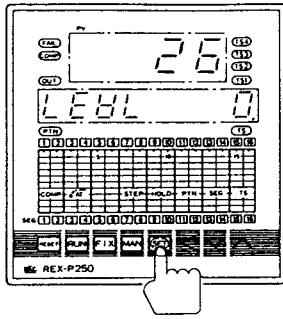

- ① First, in order to set the controller to the setting enable state, confirm that the LED in the SET key section lights. If it is not lit, light it up by referring to Item "Set data locking function" on page 12. Simultaneously, confirm that the controller is not in the computer mode.

Press the **[SET]** key a few times to display the level set-value.

Setting using the character display unit and the **[←]** and **[→]** keys.

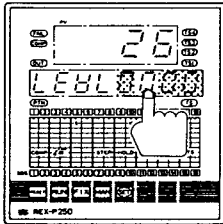

Setting using the **[←]**, **[→]**, and **[SET]** keys.

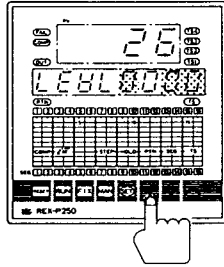

- ②₁ Change the level set-value. The lower 4 digits from the least significant digit (LED) on the set-value (SV) character display unit are also used as key switches. By pressing any digit section desired to be changed, it lights up brightly. The digit lit brightly can be changed. When changing 0°C to 200°C, press the key switch corresponding to the third digit from the least significant digit.

- ②₂ Change the level set-value. Pressing the **[←]** key once lights only the least significant digit (LED) brightly on the character display unit. The digit lit brightly is settable. When changing 0°C to 200°C, press the **[←]** key 3 times.

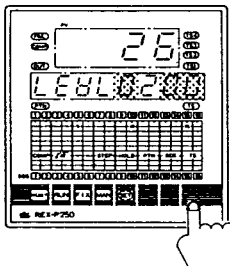

- ③ Set the digit lit brightly using the **[←]** and **[→]** keys. Display 200 by pressing the **[←]** key twice.

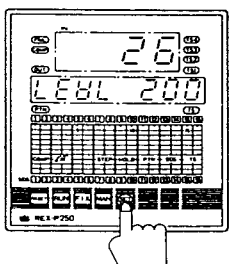

- ④ After the numeric value is set, press the **[SET]** key to have finished the setting. Confirm that all of the digits corresponding to the set value light brightly and then press the **[SET]** key again. Thus the display unit shows the segment time setting characters. Therefore conduct the setting in the same way as level setting.

- ⑤ Thus, the setting has been finished. If key operation is not performed for more than 30 sec., the current display returns to the monitoring display. In this case repeat the setting procedure from ①. If no more set-value change is required, lock the data by referring to Item "Set data locking function" on page 12.

Notes Use care of the following for data setting.

- This controller uses the parameter in any digit at the time it was changed.
- This controller can shift the digit up and down when each parameter is changed.
For example, if "199°C" is necessary to be changed to "200°C", first shift the digit lit brightly to the least significant digit, then press the **[←]** key to increase the set value from "9" to "0", thereby obtaining 200°C. This procedure is also applied to shift the digit down.
- Set a minus sign (-) in accordance with the following procedure.
(Example)
In order to change 200 to -100, shift the digit lit brightly to the hundreds digit, and then press the **[←]** key to decrease numeric values in order of 1 → 0 → -1.
- The number of digits to be lit brightly or dimly varies with the parameter type. This means that the effective setting digit corresponding to that parameter lights brightly or dimly. However, when the effective setting digit corresponds to the units digit, the tens digit lights dimly for convenience.

(Example 1) For PID memory No. setting

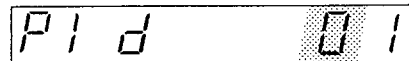

Since the effective setting digit corresponds to the units digit, the tens digit lights dimly for convenience, but the digit lit brightly cannot be shifted.

(Example 2) For time signal output No. setting



Since the 3rd and 4th digits from the LED are not effective setting digits, they cannot be lit brightly.

(Example 3) For segment time setting



For this setting, digits up to the 6th digit are effective.

- When the set-value (SV) character display unit displays other than the current operation mode monitoring display, the present display returns to the monitoring display if key operation is not performed for more than 30 sec. However, this does not apply when the display unit displays a parameter in the "Common setting group".
- Always operate the keys with fingers.

* The sections enclosed with  on the set-value (SV)/character display unit in the above Fig., indicate that they light up dimly.

4. OPERATION MODE STATUS TRANSITION

● Operation mode status transition diagram

This controller roughly has 4 modes as shown in the following Fig., and it enables you to confirm and set a parameter in each setting group even if it is in any operation mode.

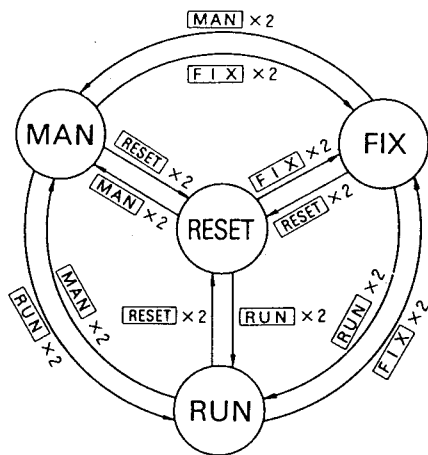

- RESET** (○) Reset mode (The reset lamp lights.)
- RUN** (○) Program control mode (The RUN lamp lights.)
- FIX** (○) Fixed set-point control mode (The FIX lamp lights.)
- MAN** (○) Manual control mode (The manual lamp lights.)

Key operation

- RESET** × 2 Press the RESET key twice in succession.
- RUN** × 2 Press the RUN key twice in succession.
- MAN** × 2 Press the MAN key twice in succession.
- FIX** × 2 Press the FIX key twice in succession.

* Always operate the keys with fingers.

4.1 **RUN** Setting in RUN program operation mode.

a) Program setting group

- When the lamp in the SET key section lights, this setting is available. (12) (1-7) (The setting can be confirmed even when the lamp is extinguished.)

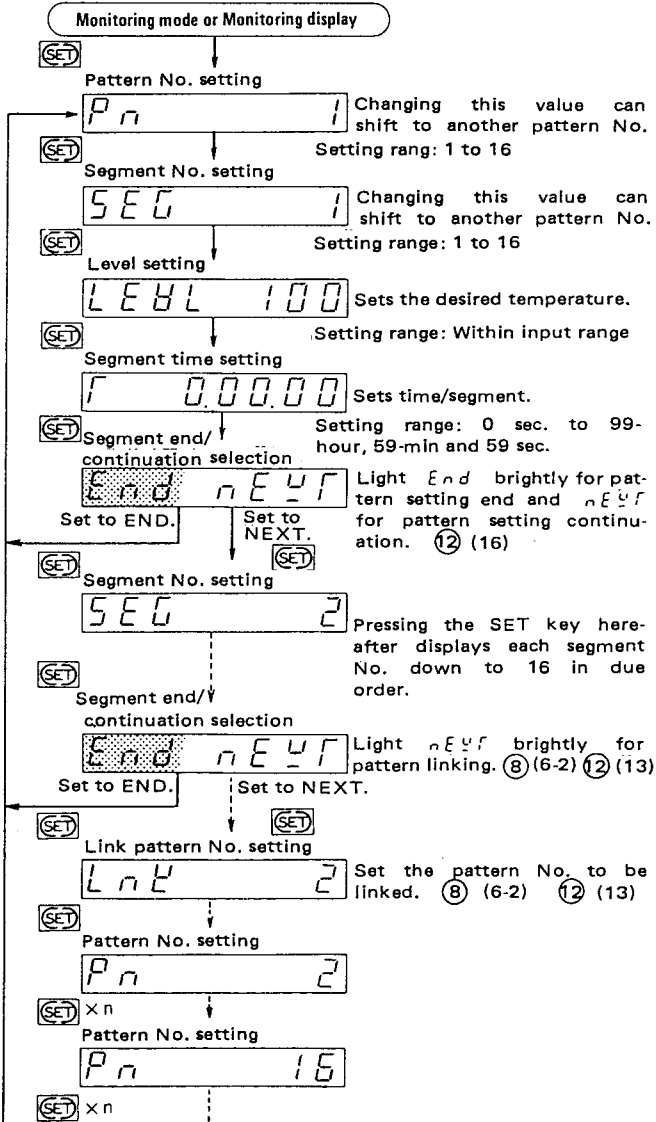

■ Monitoring mode

- This is a mode used for confirming the status in the program control mode. Each parameter is not settable.

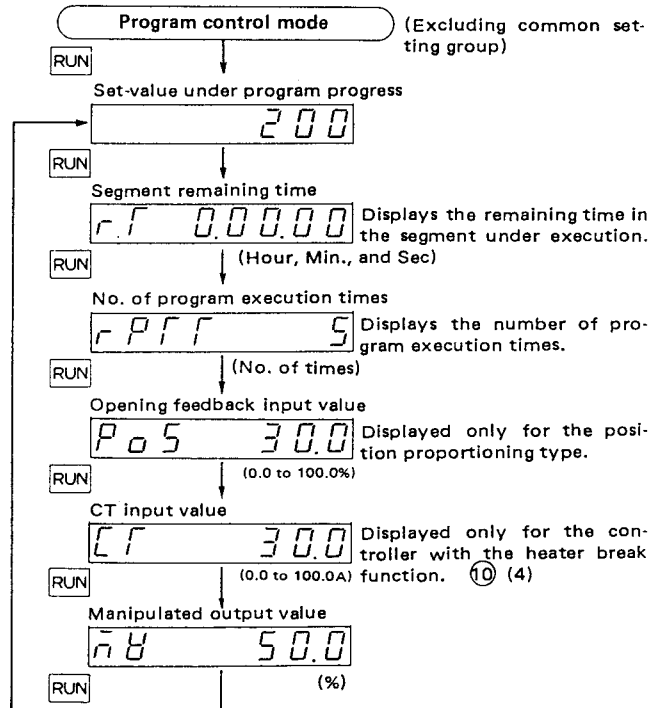

Precautions Precautions related to each setting group

1. The numeric value corresponding to each parameter is one example.
 2. If key operation is not performed for more than 30 sec, the current display returns to the monitoring display.
 3. If the key switch corresponding to any of the upper 4 digits from the most significant digits (MSD) on the set-value (SV)/character display unit is pressed by mistake during setting, the display suddenly jumps to the "Memory setting group". In this case, call up the setting group already set again and continue the setting.
 4. Always operate keys with fingers.
 5. Even if the level and time of the segment under execution are changed, they are not captured, but captured from those under the next execution.
 6. O and () in the above Fig. show the reference pages.
- * Items 2 and 3 above are excluded when each parameter in the "Common setting group" is displayed.

b) Pattern setting group

- Group to be set for each pattern.
- This setting is available while the LED in the SET key section lights. (12) (17)
(The setting can be confirmed even when the LED is extinguished.)

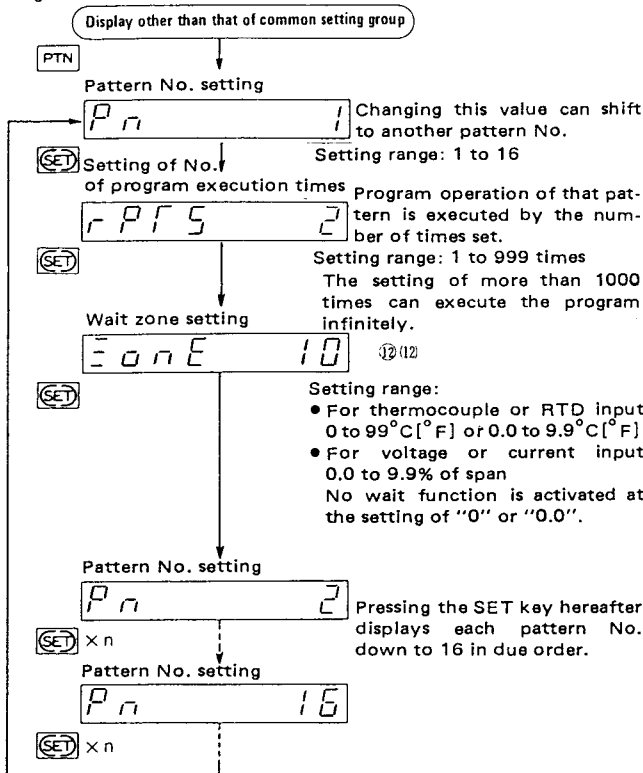

c) Segment setting group

- Group to be set for each segment.
- This setting is available while the LED in the SET key section lights. (12) (17)
(The setting can be confirmed even when the LED is extinguished.)

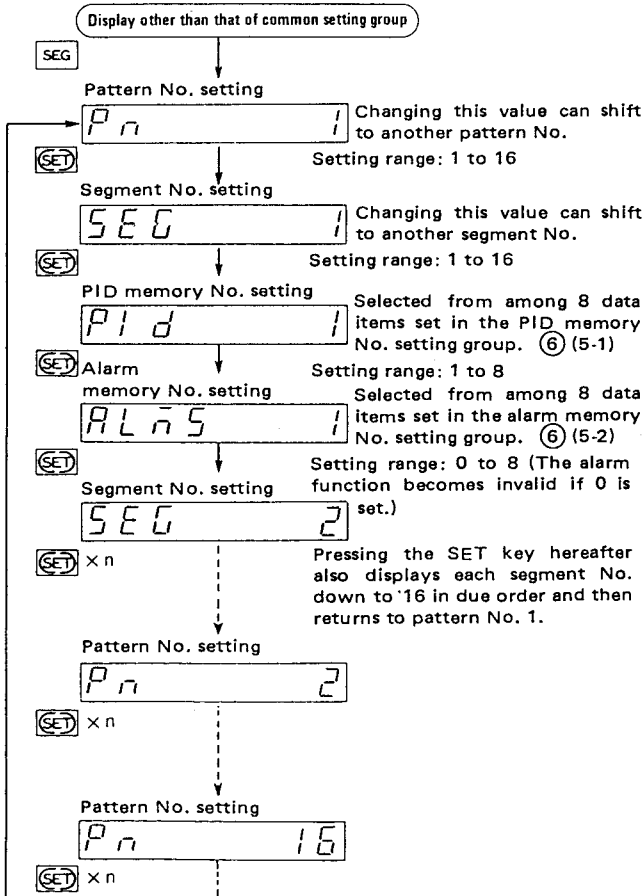

d) Time signal setting group

Four open-collector output signals can be output as program time progresses. Up to 16 times/pattern can be set.

- Item to set time signal output timing.
- This setting is available while the LED in the SET key section lights. (12) (17)
(The setting can be confirmed even when the LED is extinguished.)

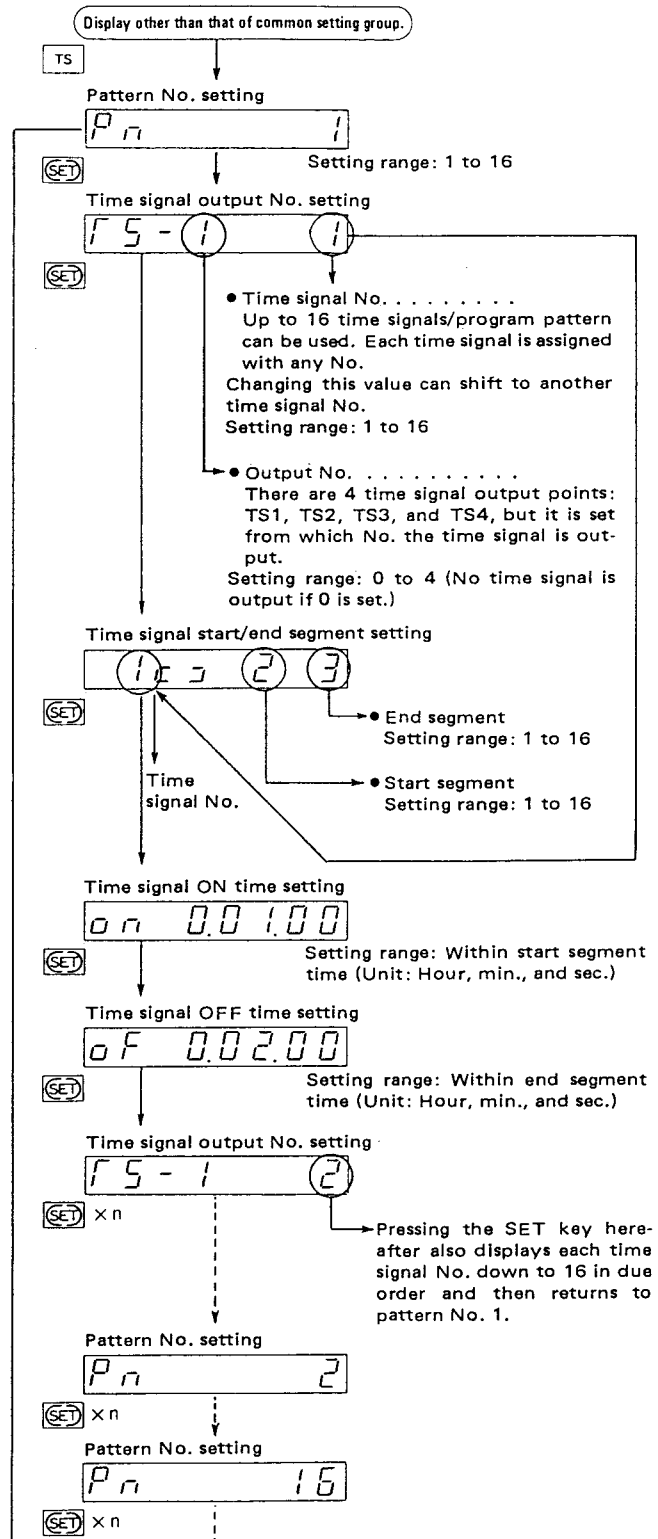

* In the example shown above, time signal No. 1 continues to be output until the lapse of 2 min. in the 3rd segment from the lapse of 1 min. in the 2nd segment.

4-2 [FIX] Setting in fixed set-point control mode

- This setting is available in any operation mode.
- The setting is available while the LED in the SET key section lights. (12) (17) (The setting can be confirmed even when the LED is extinguished.)

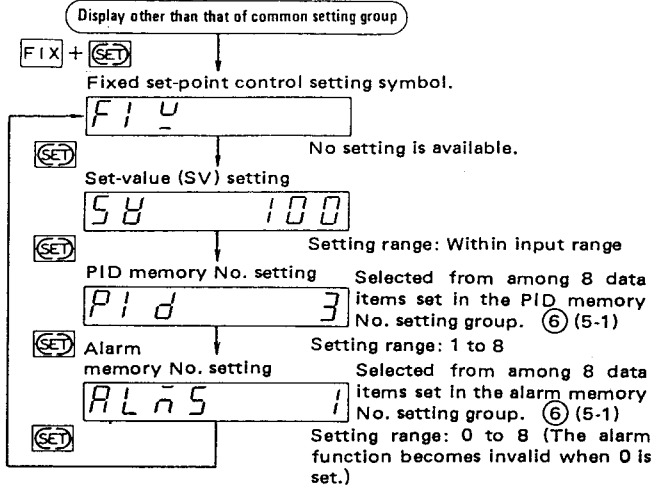

* When the controller enters the fixed set-point control mode during program control, program control continues holding the set-value at that time.

Monitoring mode

- This display is used for confirming the status in the fixed set-point control mode.
- Each parameter is not settable.

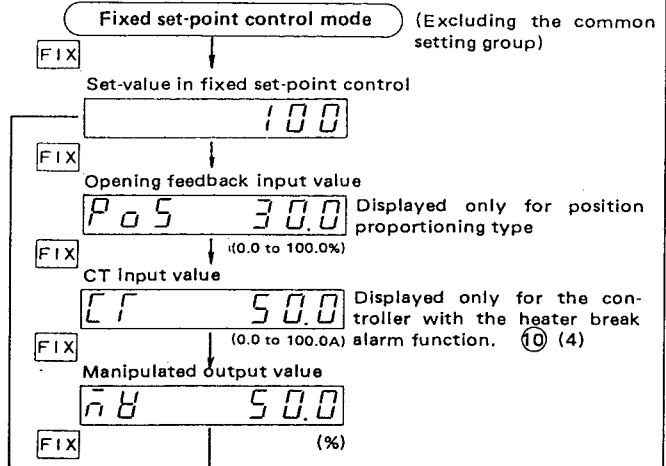

5. MEMORY SETTING GROUP/Common Setting Group

5-1 PID memory No. setting group

- Eight settings of PID constants, etc. can be stored in memory.
- This setting is available while the LED in the SET key section lights. (12) (17) (The setting can be confirmed even when the LED is extinguished.)

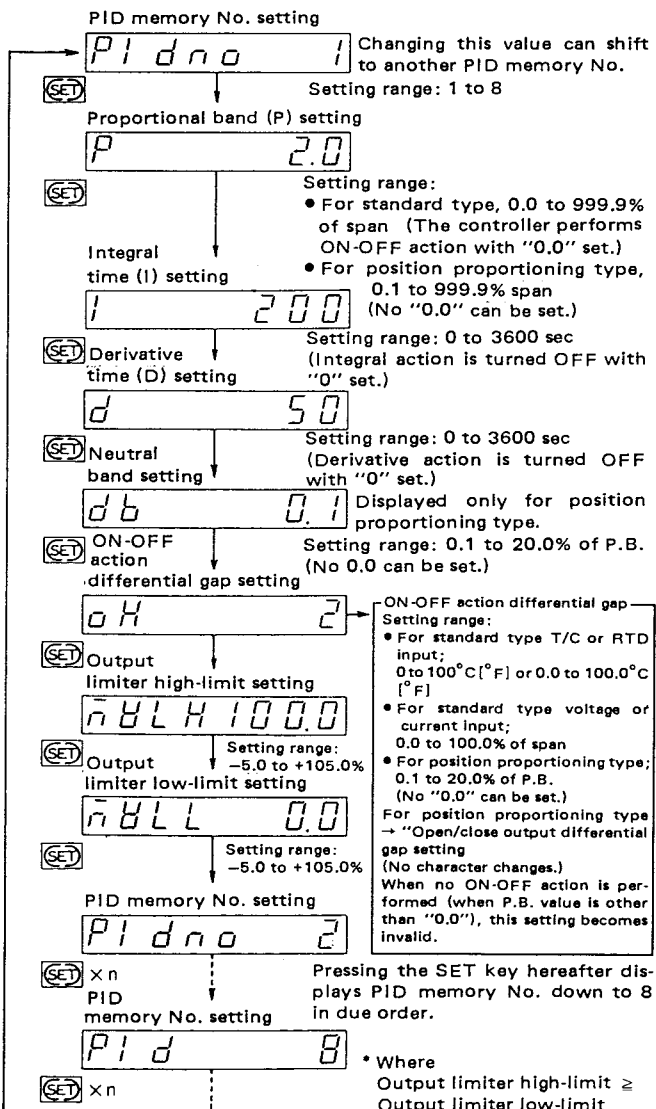

How to call up setting group

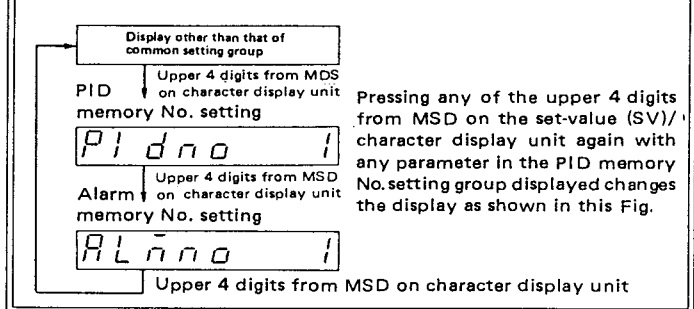

5-2 Alarm memory No. setting group

- (Not displayed for the controller without the alarm function)
- Eight alarm set-values can be stored in memory.
- This setting is available while the LED in the SET key section lights. (12) (17) (The setting can be confirmed even when the LED is extinguished.)

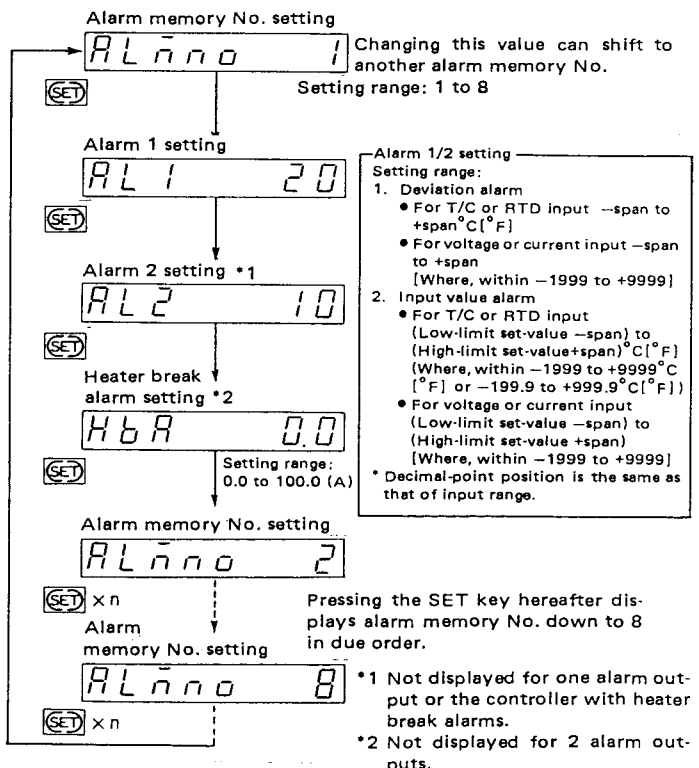

6. SET DATA EXAMPLE

6-1 Program pattern setting method

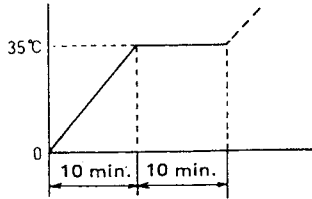

Program setting example as shown in the above Fig.
(Example when the value set before shipment is changed.)

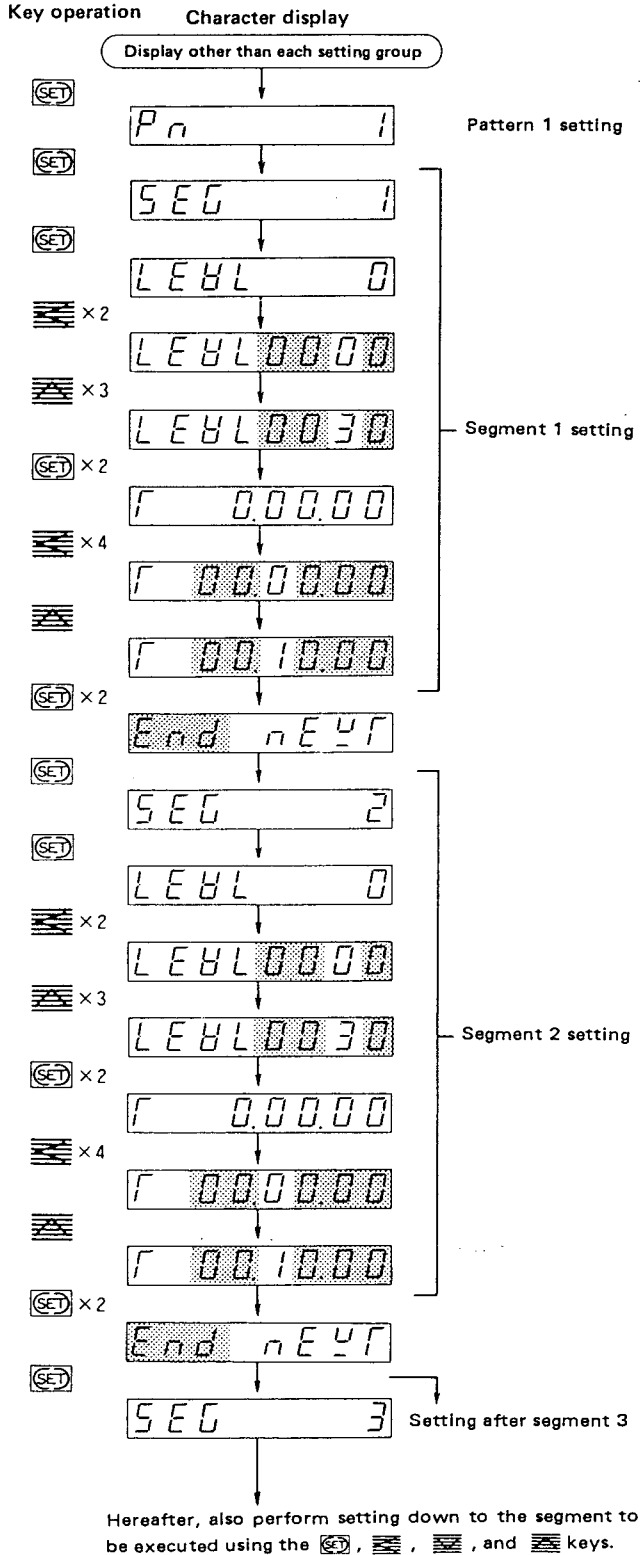

6-2 Pattern linking method

For linking from pattern 2 to pattern 5.
(Example when the value set before shipment is changed.)

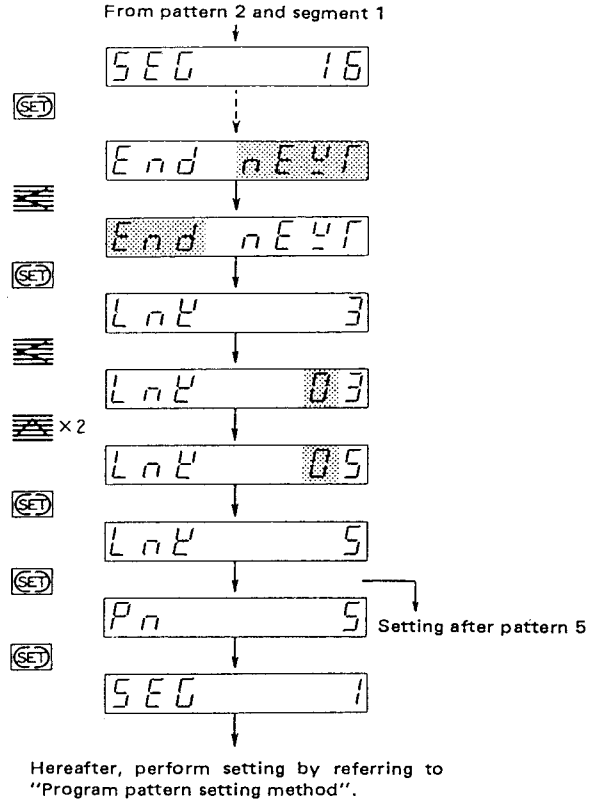

6.3 Fixed set-point control setting method

For setting SV value 0°C to 50°C
(PID No. 2, and ALM No. 1)

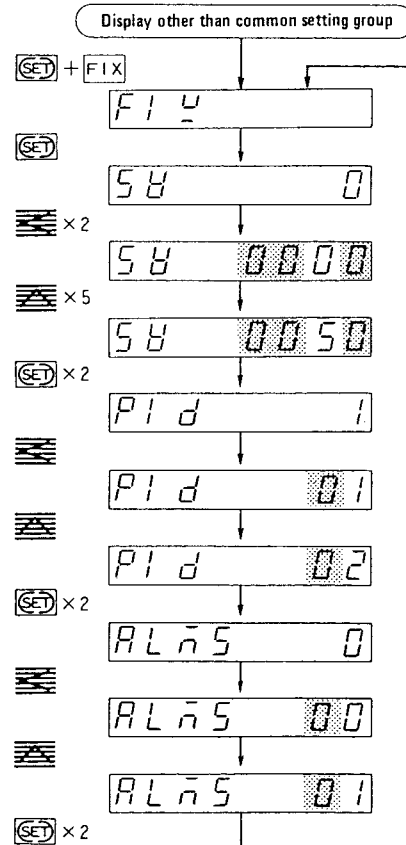

* Sections enclosed with  on the set-value (SV)/character display unit in the above Fig. indicate those lit dimly.

7. PRIOR TO OPERATION

7-1 Setting in the user initial setting mode

Prior to starting operations, carry out setting in the user's initial setting mode.

(a) Preparation

As shown in Fig. 1, pull out the internal chassis from the housing while pushing up the stopper at the bottom of the instrument with fingers. Thus, it can be withdrawn from the housing. Next, as shown in Fig. 2, turn ON the internal switch A at the top of the instrument, then push the internal chassis into the housing. Thus the instrument is set to the user initial setting mode.

In order to exit from the user initial setting mode, turn OFF the internal switch shown in Fig. 2.

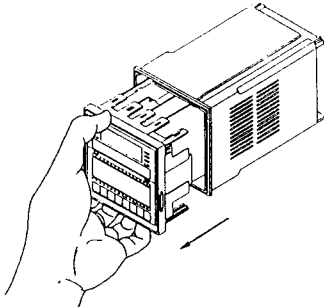

Fig. 1

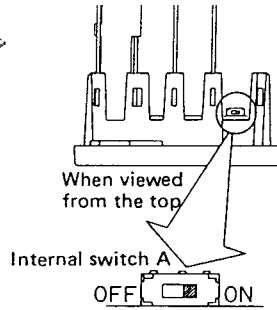

Fig. 2

(b) Parameter descriptions

Entering the user initial setting mode causes the measured-value (PV) display unit and the set-value (SV)/character display unit to show "b P 5". Then, pressing the **[SET]** key changes the setting item as follows. (When one cycle is complete, it returns to the first item, "b P 5".)

Measured-value (PV) display unit	Name	Description	Initial value at shipment
b P 5	Communication rate setting	No display is made if this controller is not provided with the communication function. For these settings, refer to "Communication Instruction Manual" separately prepared.	4800
b I F	Data forms setting		072
R d d	Device address setting		0
I n F	Interval time setting		120
P d	Start mode selection	This parameter sets the initial instrument status at recovery from power failure or power ON.	
		Set-value	Description
		0	Cold start in the reset mode (All outputs are OFF.)
1	Cold start in the manual mode (Output is the output limiter (Low limit) value.)		
2	Hot start (Status before power is turned OFF.)		
		For an instantaneous power failure of less than 4 seconds, the instrument performs a hot start regardless of the setting.	0
S Y S F	Set-value (SV) selection at start	This sets the level at which the set-value (SV) starts when program control is executed.	
		Set-value	Description
		0	Starts set value (SV) from level 0.
1	Starts set value (SV) from measured value (PV).		
C L R	Data all clear setting	Setting "9999" cancels all data excluding the user initial setting and causes the initial value to appear. Conduct this setting according to character display and setting using the [F1] and [F2] keys in "3. FUNDAMENTALS OF DATA SETTING" on page 3. Setting other than "0" or "9999" cannot be achieved.	
			0

* Setting can be done only with the **[F1]** key.

7-2 Opening adjustment

(For the position proportioning type)

This instrument has already been adjusted at shipment to the resistance value corresponding to opening feedback input. However, if fine adjustment needs to be made, do it in the following way. In this case, check connections and make sure that loads such as the control motor operate.

(a) Wiring procedure

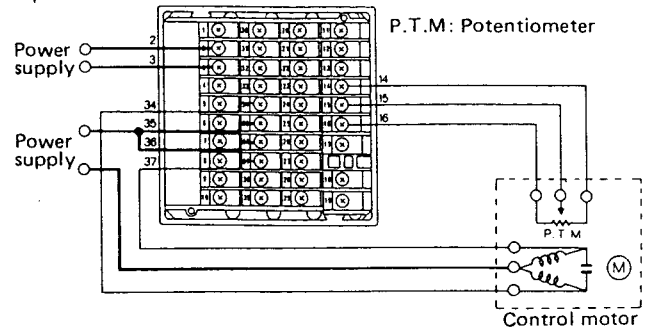

(b) Adjustment procedure

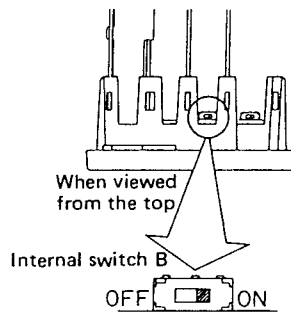
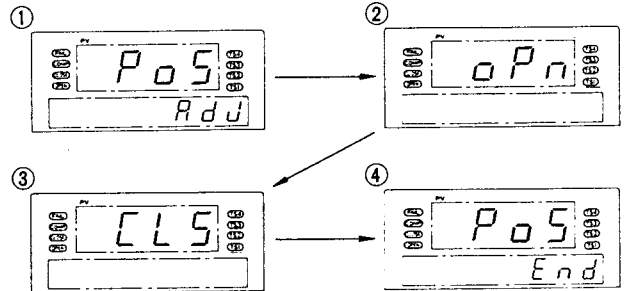

Fig. 3

Pull the internal chassis from the housing as shown in Fig. 1, turn the internal switch B on the top of the instrument to ON as shown in Fig. 3, then return the internal chassis to the housing. Turning the power supply ON causes the display units to display parameter as shown in ① below. Pressing the **[SET]** key starts adjustment, and the display automatically changes in the order of ① → ② → ③ → ④ shown below. Adjustment is complete when display ④ appears. Then, turn the internal switch B shown in Fig. 3 to OFF to return to the normal status.



Caution

Pay much attention that load such as control motor operates during adjustment.

7-3 How to use pattern cards

This instrument is capable of programming 16 control patterns in program control. Therefore, the control processes are on pattern cards which are mounted on the instrument's front panel to allow you to check the control pattern at a glance. (Ten pattern cards (for 20 patterns) are attached.)

(Example)

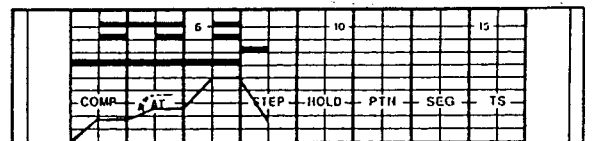

- ① The vertical line shows levels in which one scale division is 20°C, while the horizontal line shows segments in which each scale division represents one segment.
- ② The lines at the upper section of the graph show segments where the time signal is turned ON. As there are 4 time signal outputs, each scale division from the top is regarded as TS1, TS2, TS3, and TS4 respectively.

* If instruments are mounted just along the sides of the controller, no pattern card can be inserted into the controller. Therefore in this case, slightly pull out the internal chassis of the controller as shown in Fig. 1 and then insert the card into the controller.

8. HOW TO START PROGRAM OPERATION

Example: When starting program operation from pattern No. 3

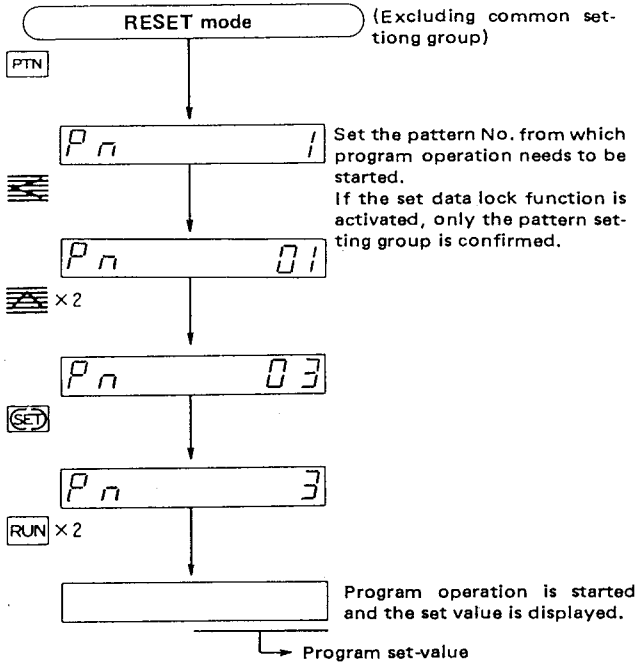

9. DESCRIPTION OF MAIN FUNCTIONS

(1) Program progress accelerating/reversing function

Program progress speed can be accelerated only when the key is pressed during program operation. Speed will continue to increase as this key is being pressed. Further pressing of the key advances the program to execute the linked pattern or program operation using the repeat number. Program progress can also be reversed while the key is being pressed. This reverse speed further increases as this key continues to be pressed. Continued pressing of the key returns the segment, then the linked pattern to the previous pattern, and all the way back to pattern start: segment 1. However, for the repeat set pattern, the number of setting times returns only to the segment 1 pattern during operation.

This operation is the same as normal operation during activation of this function. Also time and control output change as time progresses and time signal is also turned ON/OFF. Neither accelerating nor reversing is activated in the set lock/END status.

(2) Self-diagnostic function

Check item	Display during trouble occurrence
Set data check	Displays "Err" or error code No. on the measured value (PV) display unit.
Input data check (Measured-value input/ current transformer input)	
RAM check	
CPU power monitoring	FAIL indicating lamp lights up.
Watch dog timer	All other displays lights out.

(a) Error codes

- ① Error 1 (Err 1) ... CPU error
 [Cause] : Influence by noise, etc.
 [Remedy] : Turn the power OFF once, then turn ON again. However, if the error still occurs contact our service department.
- ② Error 2 (Err 2) ... RAM error
 [Cause] : Backup battery is dead and/or RAM is faulty.
 [Remedy] : Contact our service department.

- ③ Error 3 (Err 3) ... Data error
 [Cause] : Electrical noise, incorrect setting, etc.
 [Remedy] : Check each setting item, again, (Especially, time signal and linked pattern No. settings) However, if the error still occurs, contact our service agency.
- ④ Error 4 (Err 4) ... A/D conversion error
 [Cause] : A/D converter trouble, etc.
 [Remedy] : Contact our service agency.

(b) Output status during trouble occurrence

- Control output (relay contact, voltage pulse, Triac drive trigger) and alarm output OFF
- Control output (current, continuous voltage) and analog output -5.0% or less
- FAIL output (Contacts keep being closed during error code display.) Contact open

(3) Alarm (ALM) function

Up to 2 alarm output points are available. When alarm 1 is activated, the set-value(SV)/character display unit flashed "AL 1". (For alarm 2, "AL 2") When both the alarms are activated, the display unit flashes "AL 1" and "AL 2" alternately.

The action of each alarm is as shown in the following.

(▲ : Set-value (SV) ▲ : Alarm setting)

Deviation alarm

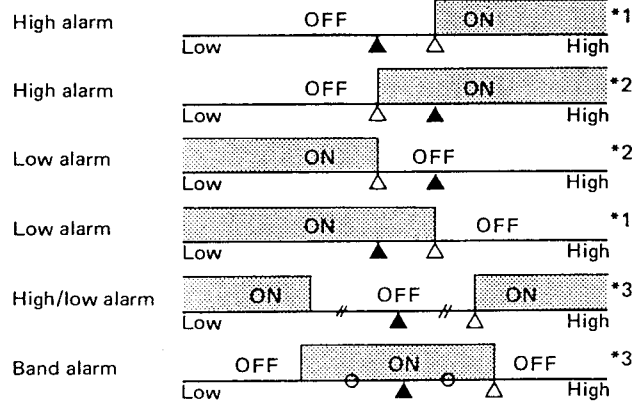

Process alarm

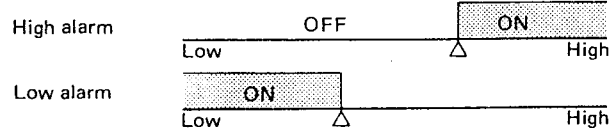

- *1 Alarm status where the alarm set-value is set to plus (+).
- *2 Alarm status where the alarm set-value is set to minus (-).
- *3 Status where alarm is activated at 2 equal deviation points from the set-value (SV) with alarm set-value (absolute deviation) is set.

(4) Heater break alarm (HBA) function

- ① When the heater break alarm is activated, the set-value (SV)/character display unit flashes "Hb A".
- ② It is desirable that basically the heater break alarm be set to about 85% of a current transformer input value, "E". However, when power supply variations are large, set the alarm to a slightly smaller value. In addition, when two or more heaters are connected in parallel, set the alarm to a slightly larger value so that it is activated even with only one heater is broken. (However, within the value of "E".)
 * The heater break alarm is set in accordance with "Alarm memory No. setting group." (Refer to page 6.)
 The current transformer input value can be checked by Monitoring display. (Refer to page 16.)

Caution For current control output or continuous voltage control output, no heater break alarm can be used.

(5) Auto-tuning (AT) function

The auto-tuning function measures, calculates and sets the optimum PID constants automatically. It is used in the program control or fixed set-point control mode.

- ① Pressing the **AT** key twice starts auto-tuning. The set-value (SV)/character display unit flashes "RTU" while the auto-tuning function is activated.
- ② When the function ends its activation, "RTU" stops flashing. The PID constants thus computed are automatically written into the PID memory No. already selected at the time of auto-tuning start, and as a result the PID constants stored before this time are erased.
- ③ If it needs to confirm the auto-tuned constants, call up the PID memory No. setting group (page 6). Also, change the auto-tuned constants in accordance with "3. FUNDAMENTALS OF DATA SETTING" (page 3).
- ④ When suspending the auto-tuning function halfway, press the **AT** key twice. In this case, no PID constants are changed. (The values before auto-tuning start)
- ⑤ Auto-tuning execution in a soak level (fixed set-point control sections in program control) during program control can obtain a good controlled result. Also, program progress is automatically held during auto-tuning execution and the program automatically restarts after the auto-tuning function is finished.

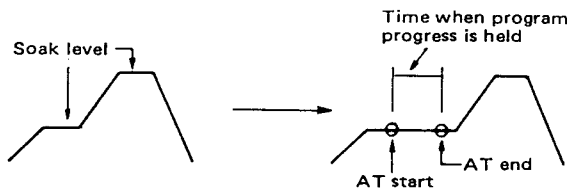

- ⑥ Auto-tuning function progress is suspended when:
 - the operation mode is changed.
 - the PV bias value is changed.
 - the set-value (SV) is changed during fixed set-point control.
 - an error occurs.
 - an input wire is disconnected.
 - the auto-tuning function does not end after the lapse of about 9 hours from its start.
 - However, when power failure occurs (including instantaneous power failure within about 4 sec.) and then recovers during auto-tuning execution, the auto-tuning function is not cancelled but is started from the beginning. [Only when hot start is selected in the user initial set mode]

(6) Auto-tuning learning function (ATT)

The PID constants vary with the level to be set even at the same load. For this reason, the auto-tuning function must be executed for each segment in program control. However, if the auto-tuning function is learned, each program soak level (fixed set-point control section in program control) is automatically detected for executing the auto-tuning function, and up to 8 PID constants are stored in a PID memory No. setting group from PID memory No. 1 in executing order.

After confirming whether or not the values thus stored are appropriate, set up a program to be executed. The auto-tuning learning function can be used only in the reset mode. This setting is made in accordance with "Common setting group". (Refer to page 7.)

(7) External contact input

Pattern No., reset mode and program control mode settings, and step and hold functions can be performed by not only front keys but also contact input from the rear terminals.

- ① Pattern No. setting
A pattern No. is selected according to the open/close status of rear terminal Nos. from 20 to 24. If rear terminals, Nos. 20 and 25 (P.SET) are closed, the selected data is captured. This is effective only in the reset mode.

Pattern No. selection according to terminal status

Terminal No.	1	2	3	4	5	6	7	8	9	10	11	12	13	14	15	16
Pattern No.																
No. 20 - 21	X	O	X	O	X	O	X	O	X	O	X	O	X	O	X	O
No. 20 - 22	X	X	O	O	X	X	O	O	X	X	O	O	X	X	O	O
No. 20 - 23	X	X	X	X	O	O	O	O	X	X	X	X	O	O	O	O
No. 20 - 24	X	X	X	X	X	X	X	X	O	O	O	O	O	O	O	O

X : Open O : Close (No.20 : Common)

- ② Reset mode setting
If rear terminals, Nos. 20 and 26 (RESET) are closed, the operation mode is set to the reset mode.
- ③ Program control mode setting
If rear terminals, Nos. 20 and 27 (RUN) are closed, the operation mode is set to the program control mode.
- ④ Step function
If rear terminals, Nos. 20 and 28 (STEP) are closed, the step function is activated. However, this is effective only in the program control mode.
- ⑤ Hold function
If rear terminals, Nos. 20 and 29 (HOLD) are closed, the hold function is activated. However, this is effective only in the program control mode.

Cautions

1. Reset mode and program control mode setting keep their statuses even if the relevant terminals are opened after being closed once.
2. When the relevant terminals are closed by external contact input in order to set the controller to the reset or program control mode, no operation mode change by the front key can be made.
3. The hold function is activated only when the relevant terminals are closed.
4. Priority is given in the order of ②, ③, ⑤, ④ and ① described above. If the terminals in higher priority are closed, those in lower priority become invalid.

(8) Overscale/underscale

- ① If a measured-value goes increasing and exceeds the high limit of the setting range due to input disconnection (or shorting), the measured-value display starts flashing. Further if it exceeds the input display range, the measured-value (PV) display unit flashes "OOOO" (overscale display).
- ② If a measured-value goes decreasing and falls below the low limit of the setting range due to input disconnection (or shorting), the measured-value display starts flashing. Further, if it falls below the input display range, the measured value (PV) display unit flashes "UUUU" (underscale display).

* For overscale and underscale display ranges, refer to "11. SPECIFICATIONS" (page 14).

When an opening feedback input wire is disconnected for the position proportioning type.

Disconnected position	Display	Control output	Alarm output
C	OOOO (Overscale)	Open side (OUT(1))	Alarm 1 (AL1)
W	UUUU (Underscale)		
O	UUUU (Underscale)	Close side (OUT(2))	Alarm 2 (AL2)
Others (2 wires or more)	UUUU (Underscale)	Both are OFF.	Both are ON.

- For disconnected positions, refer to Item 10-1 (page 13).
- Overscale or underscale is displayed on the set-value(SV)/character display unit only when an opening feedback input value (P O S) is being displayed as described.

(9) PV start

When a measured-value (PV) already reaches a certain level just at program control start, control is performed just after the start by setting the program start level to the current measured-value (PV). The PV start setting is made in the user initial set mode (page 9). (Zero start selection is also possible.)

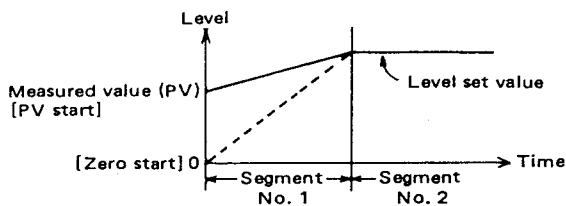

(10) Step function

If it needs to perform program control by skipping the current segment to the next segment, press the STEP key twice. Thus, the segment now in program control is skipped to perform the control from the next segment.

(11) Hold function

If it needs to suspend temporarily program progress in program control, press the HOLD key twice. Thus, the set-value (SV)/character display unit flashes "H o l d" (Hold), and as a result the control stops at the level set to the HOLD status. This status is not released even if the controller is set to any other operation mode (fixed set-point control or manual control mode). For releasing the hold status, press the HOLD key twice again.

(12) Wait function

If a measured value (PV) cannot follow program progress in program control, this function stops program movement to the next segment. When the measured-value (PV) enters within the specified value by setting a wait zone (setting of absolute deviation value with respect to level) the program moves to the next segment. The wait zone is set in accordance with "Pattern setting group". (Refer to page 5).

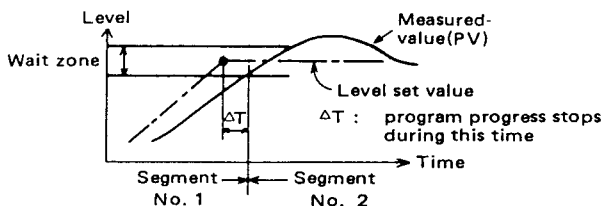

(13) Pattern link (connection) function

One pattern of this controller consists of up to 16 segments and up to 16 patterns (256 segments) can be stored. However, when one pattern consisting of 16 segments is not sufficient, a successive program with more than 16 segments can be set up by connecting more than one pattern. Pattern link setting is in accordance with "Program setting group". (Refer to page 4.)

However, when "Segment end" (segment setting group) is set in the pattern segment to be connected or setting corresponding to 16 segments is not made to the pattern to be connected, no pattern link is performed. In addition, pattern connection order can be freely set, but the same pattern cannot be connected two or more times.

(14) PV bias

If a PV bias is set for the following cases, a value obtained by adding the PV bias to a measured-value(PV) becomes an indicated value, and computation is performed using that value. A PV bias is set in accordance with "Common setting group". (Refer to page 7.)

- For thermocouple or RTD input

When an indicated value needs to be corrected because of the difference between the above indicated value and measured-value(PV) of other instruments being used simultaneously resulting from the characteristic dispersion and location of each sensor.

- For voltage or current input

When input value needs to be corrected.

(15) Digital filter

In order to reduce noise contained in a measured-value (PV), a low pass filter can be inserted. Thus, control eliminating input noise influence becomes possible by setting appropriately this filter time constant according to measured-object characteristics and noise level. This digital filter is set in accordance with "Common setting group". (Refer to page 7.)

(16) Pattern end output function

If one program ends, the set-value (SV)/character display unit flashes "E n d" (End). At this time, a pattern end signal is also output. Pattern end output time is set in accordance with "Common setting group". (Refer to page 7.)

Also, even if the pattern end output ends, "E n d" (End) goes flashing. "E n d" (End) disappears when the controller is set to the reset mode by pressing the RESET key twice.

The pattern end output enables the execution of the next process at the program end during the preset time or external counting of the number of program execution times. (The pattern end signal is output for 0.5 sec. when the program is repeated.)

(17) Set data lock function

The set data lock function makes

each set data change impossible. In order to set the controller to the set data lock state, press the character display section (any one digit in the upper 4 digits) on the set-value (SV)/character display unit while pressing the SET key. Thus, the set-value (SV)/character display unit flashes "L o c k S E T" (Lock SET) for about 2 to 3 sec. to inform the operator of the locked state. In order to release data locking,

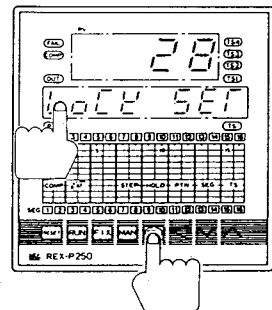

press the character display section (any one digit in the upper 4 digits) on the set-value (SV)/character display unit while pressing the SET key, again. Thus, the set-value (SV)/character display unit flashes "L o c k C l e a r" for about 2 to 3 sec. to inform the operator of lock release.

(When the controller is set to the computer mode even with the set data unlocked, each set-value cannot be changed using the front key, and also the step cannot be held during operation mode selection auto-tuning and program control (RUN).

(18) Communication function

The built-in RS-422A or RS-232C interface enables data communication with a host computer. For details, refer to Instruction Manual "REX-P250 Communication".

10. WIRING

10-1 Rear terminals

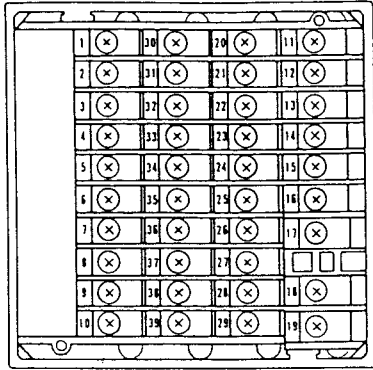

Cautions

- Each unused terminals (which varies with instrument Model) is fitted with a blind patch.
- For thermocouple input, the temperature compensation element in the internal assembly is projected through a gap between terminal Nos. 17 and 18. Do not damage the above temperature compensation element when the internal assembly is removed from the case.
- For input terminals with terminal Nos. 17, 18, and 19, use solderless terminals of 8.1mm or less wide and for the terminals with terminal Nos. other than the above, use solderless terminals 6.2mm or less wide.

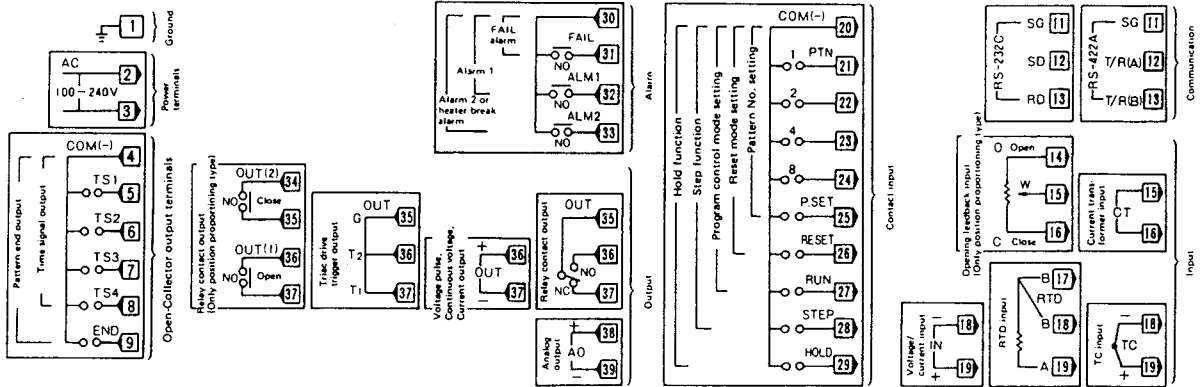
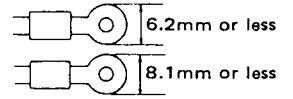

NO : Normally Open

NC : Normally Closed

COM : Common

10-2 Wiring example

o Standard type
(REX-P250^HSC-M*B-21-N)

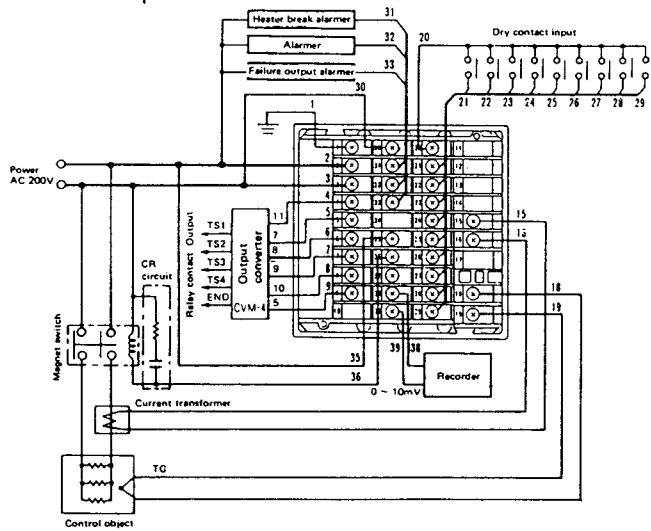

o Position proportioning type
(REX-P250YDC-M*B-N1-N)

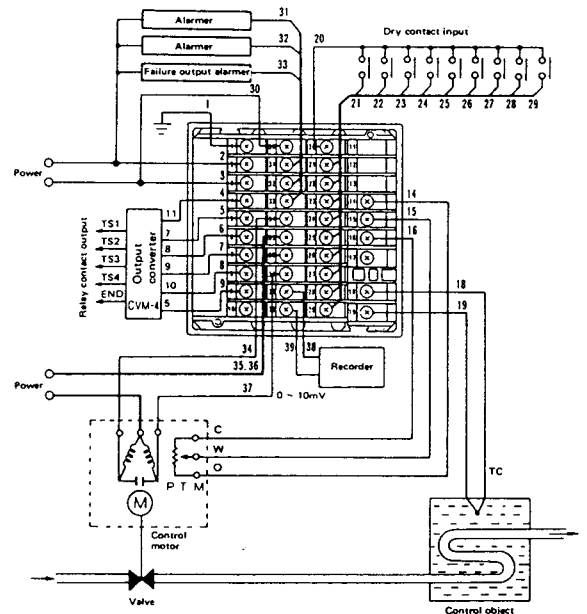

* For Models, refer to page 1.

10-3 Cautions for wiring

- Conduct input signal wiring away from instrument, electric equipment power and load lines as such as possible to avoid noise induction.
- Conduct instrument power wiring so as not to be influenced by noise from the electric equipment power. If it is assumed that a noise generation source is located near the controller and the controller is influenced by noise, use a noise filter (select the filter by checking instrument power supply voltage.)
 - Sufficient effect may not be expected depending on the filter. Therefore, select the filter by referring to its frequency characteristic, etc.

- For instrument power wiring, if it is assumed that noise exerts a bad influence upon the controller, shorten the distance between twisted power supply wire pitches. (The shorter the distance between the pitches, the more effective for noise reduction.)
- Install the noise filter on the panel which is always grounded and minimize the wiring distance between the noise filter output side and the controller power terminals. Otherwise, the longer the distance between output side and instrument power terminals, the less effective for noise.
- Do not install fuses and/or switches on the filter output signal since this may lessen filter effect.

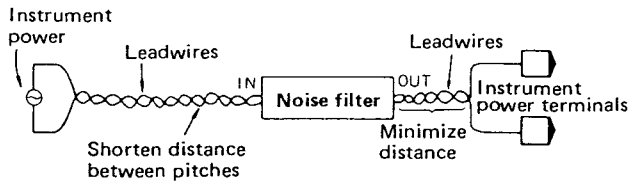

- (3) For wiring, use wires conforming to the domestic standard of each country.
(For instrument grounding, use wires with nominal sectional area of 1.25 to 2.0 mm², and securely ground the instrument at the minimum distance.)
- (4) About 1 to 2 sec. are required as the preparation time of contact output during power-ON. Use a delay relay when the output line, is used for an external interlock circuit.
- (5) The following diagram shows the REX-P250 circuit configuration. Input, MCU, output and communication circuits are mutually isolated, but the inside of the input and output circuits is not isolated. Therefore, pay attention to wiring.

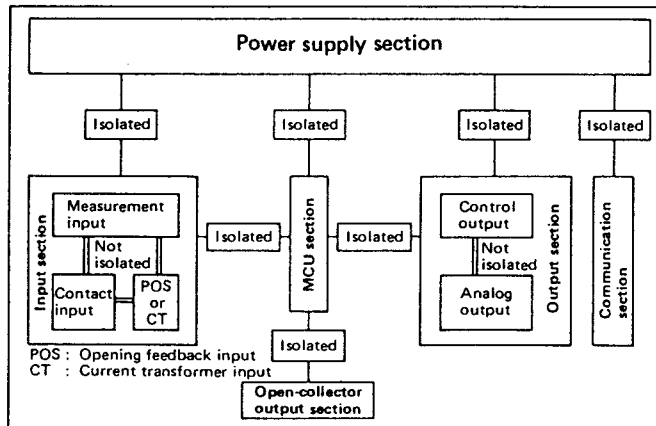

REX-P250 circuit configuration

11. SPECIFICATIONS

(1) Input

Input impedance	Thermocouple input	Approx. 1MΩ
	Voltage input	250KΩ or more
	Current input	250Ω
Influence of external resistance	Approx. 0.35μV/Ω (For thermocouple input)	
Influence of input lead resistance	Approx. 0.0075%/Ω of reading (For RTD input)	
Contact input	Input type	Dry contact input 500KΩ or more Open 10Ω or less Closed
	Contact current	4mA or less (Current flowing when each external control terminal and COMMON are shorted.)
	Contact open voltage	9VDC or less (Built-in power)
	Wiring distance	10m or less (Varies with installation environment (noise, etc.))
Opening feedback input	[Only for the position proportioning type] • Variable resistor (3 terminal): 135Ω ± 10% (For standard controller) * Other resistance values can be specified (100 to 2000Ω). • Action during input disconnection: Control output OFF for both control output open and close side • Range: Fully closed ↔ Fully open (0.0 to 100.0%)	
Sampling cycle	0.5 sec.	

Input scale range

Type	Range	Resolution	Underscale	Overscale
K	0 to 1372°C	1°C	Less than -30°C	1373°C or more
	0 to 2502°F	1°F	Less than -30°F	2503°F or more
	-100.0 to +400.0°C	0.1°C	Less than -100.0°C	400.1°C or more
J	0 to 1200°C	1°C	Less than -30°C	1201°C or more
	0 to 2192°F	1°F	Less than -30°F	2193°F or more
	-100.0 to +400.0°C	0.1°C	Less than -100.0°C	400.1°C or more
R *1	0 to 1769°C	1°C	Less than -30°C	1770°C or more
	0 to 3216°F	1°F	Less than -30°F	3217°F or more
	-148.0 to +752.0°F	0.1°F	Less than -148.0°F	752.1°F or more
S *1	0 to 1769°C	1°C	Less than -30°C	1770°C or more
	0 to 3216°F	1°F	Less than -30°F	3217°F or more
	-148.0 to +752.0°F	0.1°F	Less than -148.0°F	752.1°F or more
B *2	0 to 1820°C	1°C	Less than -30°C	1821°C or more
	0 to 3308°F	1°F	Less than -30°F	3309°F or more
	-148.0 to +752.0°F	0.1°F	Less than -148.0°F	752.1°F or more
E	0 to 1000°C	1°C	Less than -30°C	1001°C or more
	0 to 1832°F	1°F	Less than -30°F	1833°F or more
	-100.0 to +300.0°C	0.1°C	Less than -100.0°C	300.1°C or more
T	0 to 400°C	1°C	Less than -30°C	401°C or more
	0 to 752°F	1°F	Less than -30°F	753°F or more
	-199.9 to +400.0°C	0.1°C	Less than -199.9°C	400.1°C or more
N(NBS)	0 to 1300°C	1°C	Less than -30°C	1301°C or more
	0 to 2372°F	1°F	Less than -30°F	2373°F or more
	-199.9 to +400.0°C	0.1°C	Less than -199.9°C	400.1°C or more
PL II (NBS)	0 to 1300°C	1°C	Less than -30°C	1301°C or more
	0 to 2372°F	1°F	Less than -30°F	2373°F or more
	-199.9 to +400.0°C	0.1°C	Less than -199.9°C	400.1°C or more
L(DIN)	0 to 900°C	1°C	Less than -30°C	901°C or more
	0 to 1652°F	1°F	Less than -30°F	1653°F or more
	-199.9 to +400.0°C	0.1°C	Less than -199.9°C	400.1°C or more
W5Re/W26Re (ASTM)	0 to 2320°C	1°C	Less than -30°C	2321°C or more
	0 to 4200°F	1°F	Less than -30°F	4201°F or more
	-199.9 to +400.0°C	0.1°C	Less than -199.9°C	400.1°C or more
RTD	Pt100(JIS/IEC) JPt100(JIS)	0.1°C	Less than -199.9°C	649.1°C or more
	Pt100 *3 JPt100 *4	0.1°F	Less than -199.9°F	1000.0°F or more
	DC 0 to 10mV DC 0 to 100mV DC 0 to 1V DC 0 to 5V DC 0 to 10V DC 1 to 5V DC 0 to 20mA DC 4 to 20mA	Can be programmed in the range of -1999 to +9999 1. 0.1 0.01	When input becomes below (Low limit of level setting range) - (3% of span).	When input exceeds (High limit of level setting range) + (3% of span).

- *1 Accuracy in the range of 0 to 399°C (0 to 750°F):
With In ± 6°C (12°F)
- *2 Accuracy in the range of 0 to 399°C (0 to 750°F):
Not guaranteed.
- *3 Conforming to JIS/IEC
- *4 Conforming to JIS

IEC (International Electrotechnical Commission) is equivalent to JIS, DIN and ANSI.

(2) Setting

No. of Program storage patterns	Up to 16 patterns (Up to 16 segments/Pattern)	
No. of Segments	Up to 256 segments (16 patterns X 16 segments)	
No. of connectable patterns	Up to 16 patterns	
Time signal	No. of program storage patterns	16 patterns
	No. of storage times	16/pattern
No. of storage PID constants	8 memory (Selected for each segment)	
No. of storage alarm settings	8 memory (Selected for each segment)	

(3) Output

Control output	Relay contact output	250V, 3A (Resistive load) 1" contact Electrical life: 0.3 million times or more, Rated load * For the position proportioning type No. of output points: 2 250V, 3A (Resistive load) 1" contact Electrical life: 0.3 million times or more, Rated load
----------------	----------------------	--

Control output	Voltage pulse output	0/12V DC (Load resistance: 800Ω or more)
	Current output	0 to 20mA DC, 4 to 20mA DC (Load resistance: 600Ω or less)
	Continuous voltage output	0 to 5V DC, 0 to 10V DC, 1 to 5V DC (Load resistance: 1KΩ or more)
	Triac drive trigger output	Zero-cross method For medium capacity Triac (100A or less) drive ① Load voltage used: 100V AC line 200V AC line ② Load used: Resistive load
Pattern end output	Open collector output 24V DC, 50mA max. No. of output points: 1	
Time signal output	Open collector output 24V DC, 50mA max. No. of output points: 4	
Alarm output	Relay contact output 250V AC, 1A (Resistive load) 1" a" contact Electrical life: 50,000 times or more Rated load	
Fail output	Relay contact output (Open when trouble occurs.) Load 250V AC, 0.1A or less (Resistive load) 1" a" contact	

(4) Performance

Setting accuracy	Level	① Thermocouple input $\pm(0.3\% \text{ of set-value} + 1 \text{ digit})$ or $\pm 2^\circ\text{C}(\pm 4^\circ\text{F})$ (Within value whichever the greater) * For thermocouple input of R, S, and B • R, S . . . In the range of 0 to 399°C (0 to 750°F): Within $\pm 6^\circ\text{C}(\pm 12^\circ\text{F})$ • B In the range of 0 to 399°C (0 to 750°F): Not guaranteed ② RTD input $\pm(0.3\% \text{ of set-value} + 1 \text{ digit})$ or $\pm 0.8^\circ\text{C}(\pm 1.6^\circ\text{F})$ (Within value whichever the greater) ③ Voltage/current input Within $\pm(0.2\% \text{ of setting limiter span} + 1 \text{ digit})$ * Same for set-value (SV) in fixed set-point control and wait zone
	Segment time	$\pm(0.01\% \text{ of set-value})$ or 50m sec. (Within value whichever the greater) (Excluding time required for processing during segment change) * Same for time signal and pattern end output times
	proportional band	① Thermocouple/RTD input $\pm 0.5\% \text{ of setting limiter span}$ or $\pm 0.5^\circ\text{C}(\pm 1^\circ\text{F})$ (Within value whichever the greater.) ② Voltage/current input Within $\pm 0.5\% \text{ of setting limiter span}$ * Same for hysteresis band of ON-OFF action, neutral zone, and hysteresis band of open/close output
	other settings	Within $\pm 0.5\% \text{ of setting range}$
Input display accuracy	Thermo-couple	$\pm(0.3\% \text{ of displayed value} + 1 \text{ digit})$ or $\pm 2^\circ\text{C}(\pm 4^\circ\text{F})$ (Within value whichever the greater) * For thermocouple input of R, S, B • R, S . . . In the range of 0 to 399°C (0 to 750°F): Within $\pm 6^\circ\text{C}(\pm 12^\circ\text{F})$ • B In the range of 0 to 399°C (0 to 750°F): Not guaranteed

Input display accuracy	RTD	$\pm(0.3\% \text{ of displayed value} + 1 \text{ digit})$ or $\pm 0.8^\circ\text{C}(\pm 1.6^\circ\text{F})$ (Within value whichever the greater)
	Voltage/current	Within $\pm(0.2\% \text{ of setting limiter span} + 1 \text{ digit})$
Insulation resistance	Between measuring and grounding terminals; 20MΩ or more at 500V DC Between power and grounding terminals; 20MΩ or more at 500V DC	
Dielectric strength	Between measuring and grounding terminals; For 1 min. at 1000V AC Between power and grounding terminals; For 1 min. at 1500V ac	

(5) Option

Heater break alarm	Input	Current transformer output		
	Setting accuracy	Within $\pm 5\% \text{ of set-value}$ or $\pm 2\text{A}$ (Whichever the greater)		
Analog output	Output	Relay contact output: 250V AC, 1A (Resistive load) 1" a" contact Electrical life: 50,000 or more times (Rated load)		
	No. of output points	1 max.		
Analog output	Output type	Continuous voltage/current output		
	Resolution	12 bits or more		
	Output signal	0 to 10mV 0 to 100mV	0 to 1V 0 to 5V 0 to 10V 1 to 5V	0 to 20mA 4 to 20mA
	Output impedance	Approx. 10Ω	0.1Ω or less	5MΩ or more
	Allowable load resistance	20KΩ or more	1KΩ or more	600Ω or less

(6) Other specifications

Power supply voltage	90 to 264V AC (50/60Hz common use) (Including power supply voltage variation) (Rating: 100 to 240V AC)
Power consumption	15VA or less (However, 9VA or less at 100V)
Setting condition	Do not install the controller at a location where the operator needs a safeguard and/or corrosive gases exist.
Allowable ambient temperature	0 to 50°C (32 to 122°F)
Allowable humidity	45 to 85% RH
Weight	750g (1.65lb)

12. DIMENSIONS

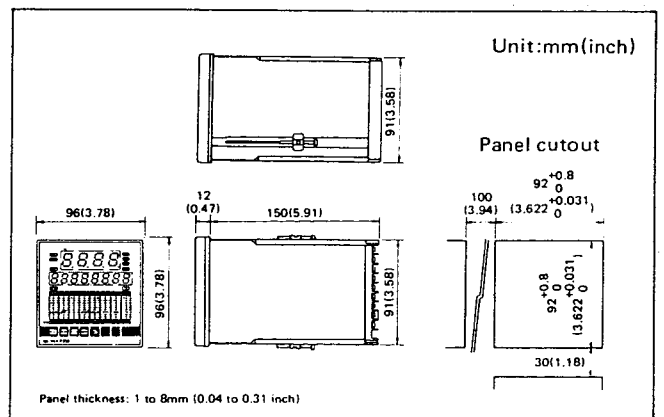

* Dimensions in inches are shown for reference.

