

CB400/CB500/CB700/CB900 INSTRUCTION MANUAL

IMCB02-E5

Before operating this instrument, please carefully read this manual and fully understand its contents. And always keep it around you to make it available easily anytime.



WARNING

- If failure or error of this instrument could result in a critical accident of the system, install an external protection circuit to prevent such an accident.
- Do not turn on the power supply until all of the wiring is completed. Otherwise electric shock, fire or malfunction may result.
- Use this instrument within the scope of its specifications. Otherwise fire or malfunction may result.
- Do not use this instrument in the places subject to flammable or explosive gas.
- Do not touch high-voltage blocks such as power supply terminals, etc. Otherwise electric shock may result.
- Never disassemble, repair or modify the instrument. This may cause electric shock, fire or malfunction.

CAUTION

- This is a Class A instrument. In a domestic environment this instrument may cause radio interference, in which case the user is required to take adequate measures.
- This instrument is protected from electric shock by reinforced insulation. So please arrange reinforced insulation to the wire for input signal against the wires for instrument power supply, source of power and loads as far as possible.
- This instrument is manufactured on the assumption that it is used in the condition of being mounted on the instrumentation panel. Therefore, take the necessary measures on the equipment side mounted with this instrument so that the operator or other personnel are not accessible to high-voltage blocks in this instrument such as power supply terminals, etc.
- Always observe precautions described in this manual. Otherwise serious injury or accident may result.
- Conduct all of the wiring in accordance with the local codes and regulations.
- Install a protection device such as a fuse, etc. in the power supply, input or output line, if necessary.
- Do not allow metal fragments or lead wire scraps to fall inside this instrument. This may cause electric shock, fire or malfunction.
- Firmly tighten each terminal screw at the specified torque. Otherwise electric shock or fire may result.
- Do not place any obstacle around this instrument in order not to impede radiation of heat. And do not close ventilation holes.
- Do not connect wires to unused terminals.
- Before cleaning the instrument, always turn off the power supply.
- Remove stains from this instrument using a soft, dry cloth. Do not use a volatile solvent such as thinner in order to avoid deformation or discoloration.
- Do not rub nor strike the display unit of this instrument with a hard object.

Notice

- This manual is subject to change without prior notice.
- Examples of figures, diagrams and numeric values used in this manual are for a better understanding of the text, but not for assuring the resultant operation.
- This manual may not be reproduced or copied in whole or in part without RKC's prior consent.
- RKC assumes no responsibility for any of the following damage which the user or third party may suffer.
 - Damage incurred as a result of using this product
 - Damage caused by product failure which cannot be predicted by RKC
 - Other indirect damage
- In order to use this instrument continuously and safely, periodic maintenance is required. Some of components and parts used in this instrument have a limited service life, or deteriorate over time.

1. PRODUCT CHECK

Check whether the delivered product is as specified by referring to the following model code list.

CB400
CB500
CB700
CB900

□□□□-□□ * □□ - □□/□/□
① ② ③ ④ ⑤ ⑥ ⑦ ⑧ ⑨ ⑩

① Control action

- F : PID action with autotuning (Reverse action)
- D : PID action with autotuning (Direct action)
- W: Heat/cool PID action with autotuning (Water cooling) *1
- A: Heat/cool PID action with autotuning (Air cooling) *1

② Input type, ③ Range code : See "8. INPUT RANGE TABLE."

④ First control output [OUT1] (Heat-side)

- M: Relay contact T: Triac V: Voltage pulse
- 8: Current (4 to 20 mA DC) G: Trigger (for triac driving)

⑤ Second control output [OUT2] (Cool-side)

- No symbol: When control action is F or D. M: Relay contact
- T: Triac V: Voltage pulse 8: Current (4 to 20 mA DC)

⑥ First alarm [ALM1], ⑦ Second alarm [ALM2]

- N: No alarm H: Process high alarm
- A: Deviation high alarm J: Process low alarm
- B: Deviation low alarm K: Process high alarm with hold action
- C: Deviation high/low alarm L: Process low alarm with hold action
- D: Band alarm P: Heater break alarm (CTL-6) *2
- E: Deviation high alarm with hold action S: Heater break alarm (CTL-12)*2
- F: Deviation low alarm with hold action R: Control loop break alarm *3
- G: Deviation high/low alarm with hold action V: SV high alarm
- W: SV low alarm

⑧ Communication function

- N: No communication function 5: RS-485 (2-wire system)

⑨ Waterproof/dustproof construction

- N: No waterproof/dustproof construction
- 1: Waterproof/dustproof construction

⑩ Case color

- N: Off-white A: Off-black

- *1: No self-tuning function is provided in the W or A control action type.
- *2: Heater break alarm can not be specified in case of ALM1. Also, it isn't possible to specify when control output is current output.
- *3: As control loop break alarm, only either the first alarm or second alarm is selected.

<Accessories>

- **Mounting bracket:** 2 pieces *1,*2
- **Mounting screws (with hexagon nuts) :** 2 pieces *1,*2
- **Instruction manual [IMCB02-E5] (1 copy)**

*1 CB400/CB500/CB700 waterproof/dustproof construction specification.: Same quantities as those on the above side also for waterproof/dustproof construction

*2 CB900 waterproof/dustproof construction spec.: 4 pieces

2. MOUNTING

2.1 Mounting cautions

- (1) This instrument is intended to be used under the following environmental conditions. (IEC1010)
 - *OVERVOLTAGE CATEGORY II *POLLUTION DEGREE 2
- (2) Avoid the following when selecting the mounting location.
 - Ambient temperature of less than 0 °C (32 °F) or more than 50 °C (122 °F).
 - Ambient humidity of less than 45 % or more than 85 % RH.
 - Rapid changes in ambient temperature which may cause condensation.
 - Corrosive or inflammable gases.
 - Direct vibration or shock to the mainframe.
 - Water, oil, chemicals, vapor or steam splashes.
 - Excessive dust, salt or iron particles.
 - Excessive induction noise, static electricity, magnetic fields or noise.
 - Direct air flow from an air conditioner.
 - Should be used indoors where the system is not exposed to direct sunlight.
 - Heat to be accumulated radiation heat.

2.2 Dimensions

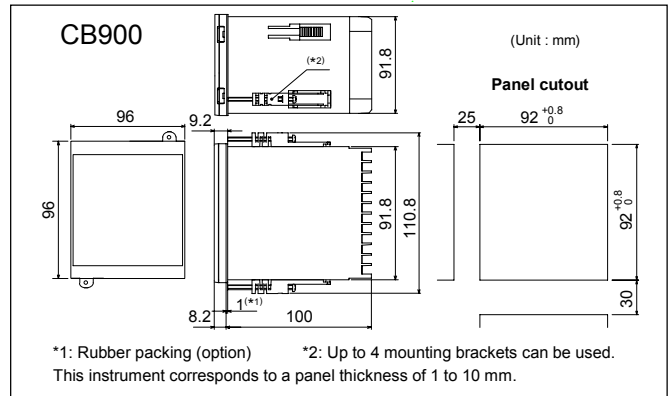
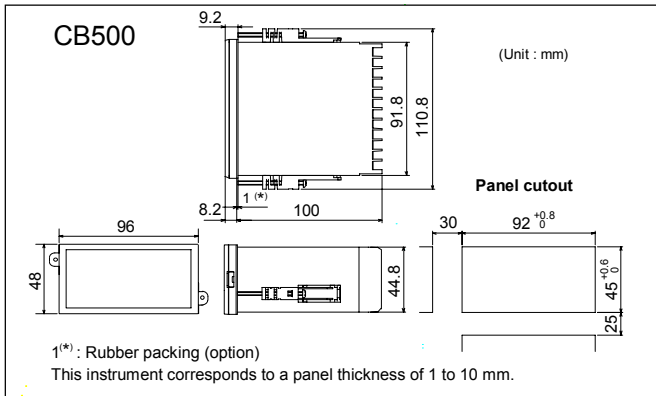
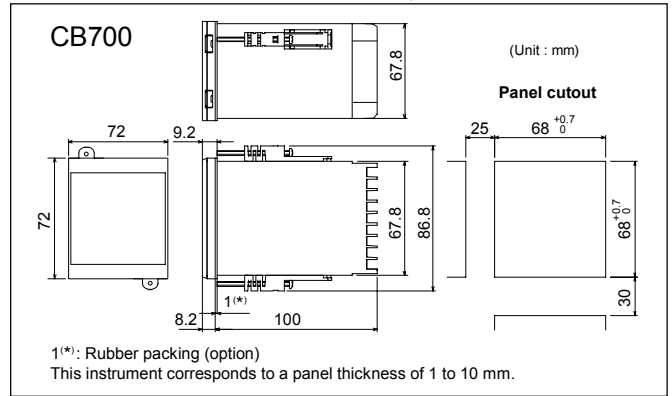
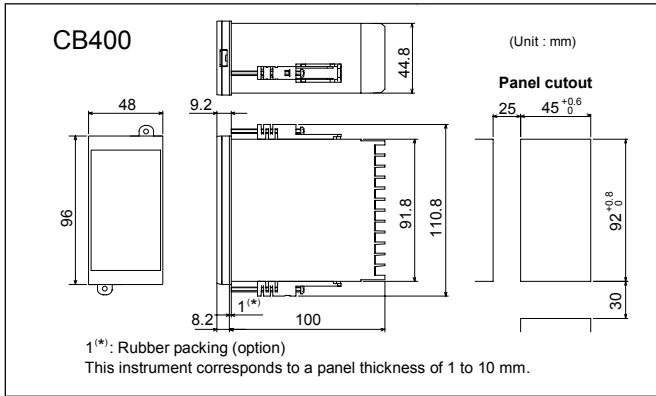

2.3 Mounting procedures

- (1) Make a rectangular holes corresponding to the number of instruments to be mounted through the panel by referring to the panel cutout dimensions.
- (2) Insert the instrument into the panel from the panel cutout.

- (3) Insert the mounting bracket into the mounting groove of the instrument.(Fig.1)
- (4) Push the mounting bracket into the instrument until the instrument is firmly fixed to the panel.(Fig.2)

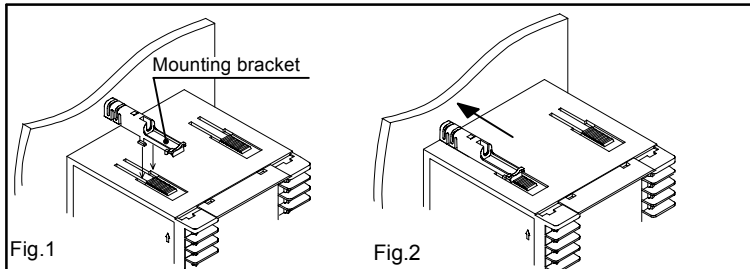

*After inserting the CB900 in the panel, fix it to the panel rear surface with the two mounting brackets so that the upper and lower mounting brackets are positioned diagonally.

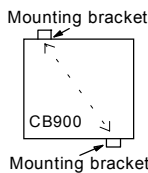

When mounting the instrument by tightening screw

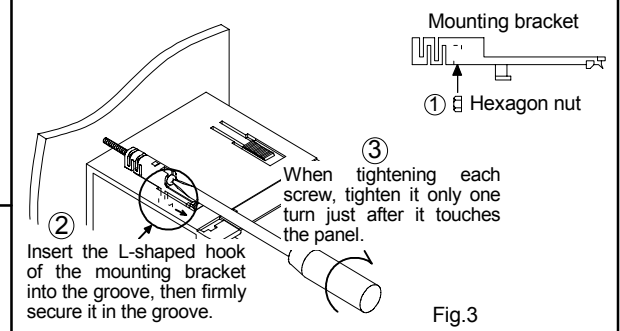

NOTES

- The front of the instrument of the waterproof and dustproof construction type (CB900: mounting bracket 4 pieces) conforms to IP65 with the instrument mounted on the control panel. In order to assure the waterproof and dustproof properties, check that there is no dislocation of the packing nor clearance between the instrument and mounting frame with the instrument mounted.
- If the packing is damaged, contact your nearest RKC agent or our sales office.
- The instrument can also be mounted by tightening screws. Insert a hexagon nut in the mounting bracket according to the above procedure (Fig. 3) to mount the bracket, then fix the instrument with the screw. Use the hexagon nuts and screws attached.
- CB900 is used in the above figures for explanation, but the same mounting procedures also apply to CB400/CB500/CB700.

3. WIRING

3.1 Wiring cautions

- (1) For thermocouple input, use the specified compensation wire.
- (2) For RTD input, use leads with low resistance and having no resistance differences among the 3 leads.
- (3) Conduct input signal wiring away from instrument power, electric equipment power and load lines to avoid noise induction.
- (4) Conduct instrument power wiring so as not to be influenced by noise from the electric equipment power. If the instrument may be affected by external noise, a noise filter should be used.
 - Shorten the distance between twisted power supply wire pitches. The shorter the distance between the pitches, the more effective for noise reduction.

- Install the noise filter on the panel which is always grounded and minimize the wiring distance between the noise filter output side and the instrument power terminals.

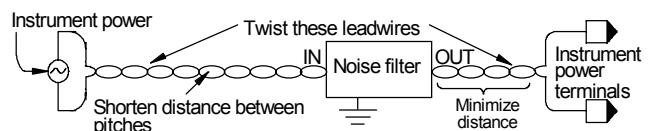

- Do not install fuses and/or switches on the filter output signal since this may lessen filter effect.

- (5) For power supply wires, use twisted wires with low voltage drop.
- (6) About 5 to 6 sec are required as the preparation time for contact output after power on. Use a delay relay when the output line, is used for an external interlock circuit.
- (7) This instrument has no power supply switch nor fuses. Therefore, install the fuse close to the instrument and the switch, if required.
 - Fuse type ; Time-lag fuse
 - Recommended fuse rating : Rated voltage ; 250 V
Rated current ; 1 A
- (8) For the current input specification, a resistor of 250Ω ($\pm 0.02\%$ $\pm 10\text{ppm}$, 0.25 W or more) must be connected between the input terminals. This resistor must be provided by the customer.
- (9) Do not excessively tighten the terminal screws. In addition, use the solderless terminal appropriate to the screw size. (Screw size: M3x6, recommended tightening torque: $0.4\text{N}\cdot\text{m}$ [$4\text{kgf}\cdot\text{cm}$])
- (10) To the instrument with power supply of 24V, please be sure to supply the power from SELV circuit.

3.2 Terminal configuration

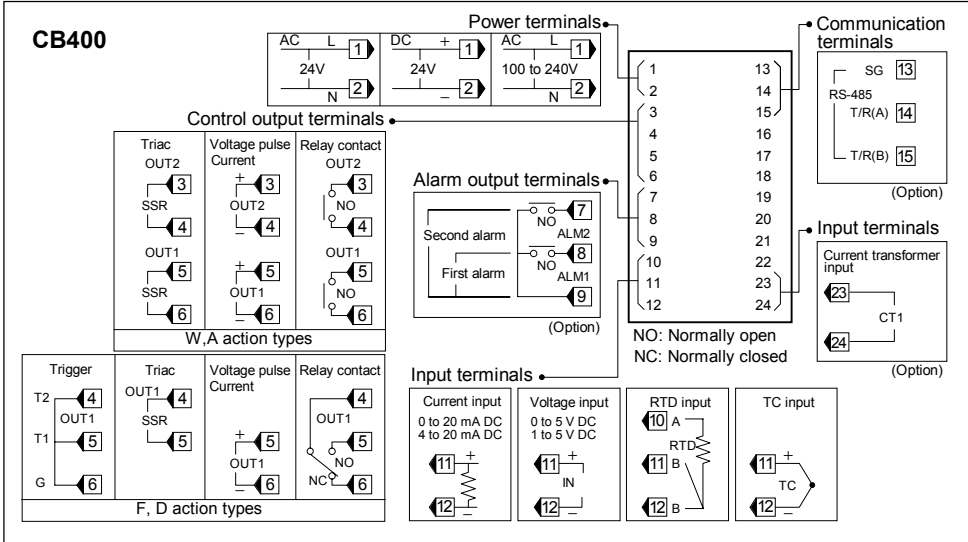

Specifications

Power supply voltage:
90 to 264 V AC [Including power supply voltage variation]
(Power frequency: 50/60 Hz)
(Rating: 100 to 240 V AC)

21.6 to 26.4 V AC
(Power frequency: 50/60 Hz)
(Rating: 24 V AC)

21.6 to 26.4 V DC
(Rating: 24 V DC)

Power consumption:
7 VA max. (at 100 V AC)
10 VA max. (at 240 V AC)
5 VA max. (at 24 V AC)
160 mA max. (at 24 V DC)

Alarm output rated:
Relay contact output :
250 V AC, 1A (Resistive load)

Control output rated:
Relay contact output :
250 V AC, 3A (Resistive load)

Voltage pulse output :
0/12 V DC
(Load resistance 600 Ω or more)

Current output :
4 to 20 mA DC
(Load resistance 600 Ω or less)

Trigger output (for triac driving) :
Zero cross method for medium capacity triac driving (100 A or less)
Load voltage used :
100 V AC line, 200 V AC line
Load used : Resistive load

Triac output :
0.5 A (Ambient temperature 40 °C or less)

Weight:

Approx. 250g (CB400, CB500)
Approx. 290g (CB700)
Approx. 340g (CB900)

NOTE

The terminal arrangement of CB500 is as shown in the following diagram, but the terminal configuration of CB500 is the same as that of CB400.

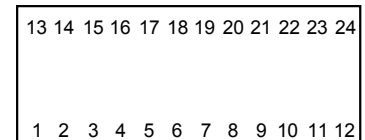

4. NAME OF PARTS

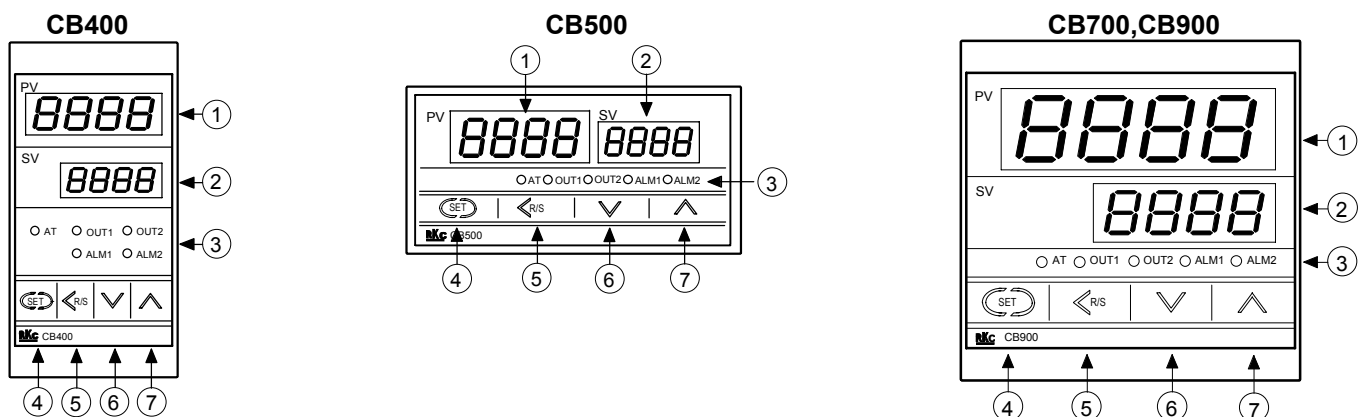

① Measured value (PV) display unit [Green]

- Displays measured value (PV).
- Displays various parameter symbols depending on the instrument.

② Set value (SV) display unit [Orange]

- Displays set value (SV).
- Displays various parameters set value (or CT input value) depending on the instrument.

③ Indication lamps

Alarm output lamps (ALM1,ALM2) [Red]

- ALM1: Lights when first alarm output is turned on.
- ALM2: Lights when second alarm output is turned on.

Autotuning (AT) lamp [Green]

Flashes during autotuning execution.

Control output lamps (OUT1,OUT2) [Green]

- OUT1: Lights when control output is turned on. **
- OUT2: Lights when cool-side control output is turned on.**

** Lamp indication becomes as follows for continuous output.

- For an output of less than 0 % : Extinguished
- For an output of more than 100 % : Lit
- For an output of more than 0 % but less than 100 % : Dimly lit.

④ Set key [SET]

Used for parameter registration/calling up.

⑤ Shift & R/S key [R/S]

- Used to shift the digit when the setting is changed. (Shift key)
- Used to select the RUN/STOP function. (R/S key)

⑥ DOWN key [V]

Used to decrease numerals.

⑦ UP key [^]

Used to increase numerals.

5. SETTING

5.1 Calling up procedure of each mode

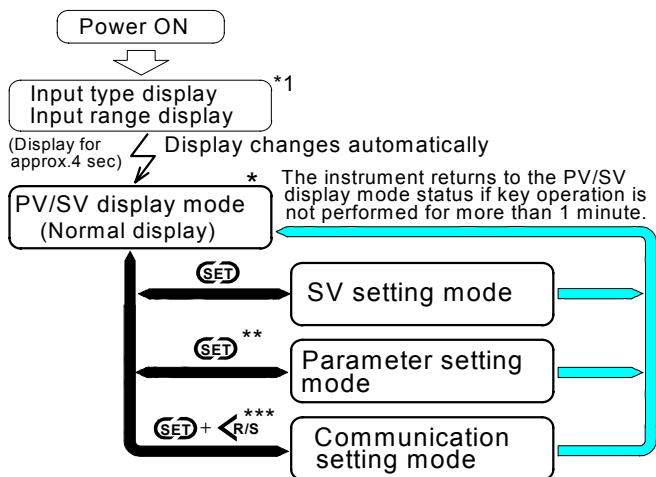

* The RUN/STOP function can be selected. The RUN/STOP function can be selected every time the <R/S> key is pressed for 1 sec.

** Press the SET key for more than 2 sec.

*** Press the <R/S> key while pressing the SET key.

*1. Input type and input range display

This instrument immediately confirms input type and range following power on.

Example: For a controller with the K thermocouple input type and range from 0 to 1372 °C.

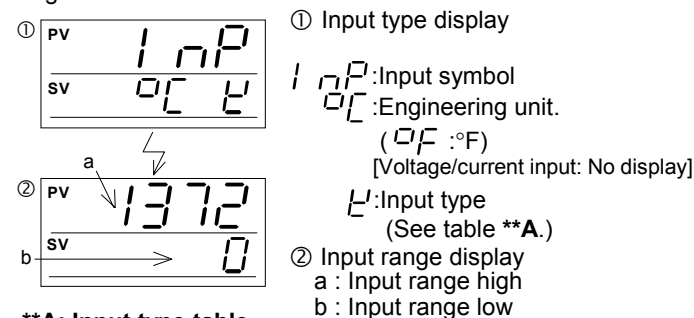

① Input type display

1 nP: Input symbol
0 C E: Engineering unit.
(0 F : °F)
[Voltage/current input: No display]

E: Input type
(See table **A.)

② Input range display
a : Input range high
b : Input range low

**A: Input type table

Display	E	J	r	S	b	E	r	n	P	U	L	J	P	A	r	H
Input type	Thermocouple (TC)										RTD		Voltage (Current)			
	K	J	R	S	B	E	T	N	PL/II	W5Re/W26Re	U	L	JPt 100	Pt 100		

5.2 Detail of each mode

■ PV/SV display mode

Display measured value (PV) on the PV display unit and set value (SV) on the SV display unit. Usually the control is set to this mode excepting that the set value (SV) and/or the parameter set value are changed. In addition, in this mode, RUN/STOP can be selected.

■ SV setting mode

This is the mode used to set the set value (SV).
Factory set value : 0 °C[°F] or 0.0 °C[°F]

■ Parameter setting mode

This is the mode used to set the various parameters such as alarms, PID constants, etc. The following parameter symbols are displayed one by one every time the SET key is pressed.

■ Communication setting mode

This is the mode to conduct settings relating to the communication function. It is displayed for the instrument with the communication function. For details on protocol, identifiers and communication setting mode, see the separate instruction manual for "Communication" (IMCB03-E□).

Parameter table

#1:Factory set value

Symbol	Name	Setting range	Description	#1
<i>CT1</i>	Current transformer input 1 (CT1)	0.0 to 100.0 A [Only display]	Display input value from the current transformer. [Displayed only when the instrument has the heater break alarm]	
<i>AL1</i>	First alarm (ALM1)	For temperature input: Deviation alarm, Process alarm, SV alarm: -1999 to +9999 °C[°F] or -199.9 to +999.9 °C[°F]	Set the first alarm set value and second alarm set value.	Temperature input: 50(50.0)
<i>AL2</i>	Second alarm (ALM2)	For voltage/current inputs: Deviation alarm : -span to +span (Within 9999) Process alarm, SV alarm: Same as input range	Alarm differential gap: Temperature input: 2 or 2.0 °C[°F] Voltage/current inputs: 0.2 % of span	Voltage/ current inputs: 5.0
<i>HbA1</i>	Heater break alarm 1 (HBA)	0.0 to 100.0 A See *1.	Alarm value is set by referring to input value from the current transformer (CT). Used only for single-phase.	0.0
<i>LbA</i>	Control loop break alarm (LBA)	0.1 to 200.0 min. (0.0 can not be set.) See *2.	Set control loop break alarm set value.	8.0
<i>Lbd</i>	LBA deadband (LBD)	Temperature input: 0 to 9999 °C[°F] Voltage/current inputs: 0 to 100 % of span	Set the area of not outputting LBA. No LBA deadband functions with "0" set. Differential gap : Temperature input 0.8 °C[°F] Voltage/current inputs 0.8 % of span	0
<i>ATU</i>	Autotuning (AT)	0: AT end or AT suspension 1: AT start	Turns the autotuning ON/OFF.	0
<i>STU</i>	Self-tuning (ST)	0: ST suspension 1: ST start	Turns the self-tuning ON/OFF.	0
<i>P</i>	Proportional band (P)	Temperature input: 1(0.1) to span or 9999(999.9) °C[°F] Voltage/current inputs: 1 to 100.0 % of span	Set when PI,PD or PID control is performed. For heat/cool PID action: Proportional band setting on the heat-side. *ON/OFF action control when set to "0(0.0)." Differential gap : Temperature input 2 or 2.0°C[°F] Voltage/current inputs 0.2 % of span	Temperature input: 30(30.0) Voltage/ current inputs: 3.0
<i>I</i>	Integral time (I)	1 to 3600 sec *PD control when set to 0 sec.	Set the time of integral action which eliminates the offset occurring in proportional control.	240
<i>D</i>	Derivative time (D)	1 to 3600 sec *PI control when set to 0 sec.	Set the time of derivative action which prevents ripples by predicting output changes and thus improves control stability.	60
<i>Ar</i>	Anti-reset windup (ARW)	1 to 100 % of heat-side proportional band. **"0" setting: integral action OFF	Overshooting and undershooting are restricted by the integral effect.	100
<i>T</i>	Heat-side proportioning cycle (T)	1 to 100 sec (0 can not be set.) *Not displayed if the control output is current output.	Set control output cycle. For heat/cool PID action: Heat-side proportioning cycle	See *3.
<i>Pc</i>	Cool-side proportional band (Pc)	1 to 1000 % of heat-side proportional band. (0 can not be set.)	Set cool-side proportional band when heat/cool PID action.	100
<i>db</i>	Deadband (db)	Temperature input: -10 to +10 °C[°F] or -10.0 to +10.0 °C[°F] Voltage/current inputs: -10.0 to +10.0 % of span	Set control action deadband between heat-side and cool-side proportional bands. Minus (-) setting results in overlap.	0 or 0.0

(Continued on the next page.)

Symbol	Name	Setting range	Description	#1
t	Cool-side proportioning cycle (t)	1 to 100 sec (0 can not be set.) *Not displayed if the control output is current output.	Set control cool-side output cycle for heat/cool PID action.	See *4.
P_b	PV bias (Pb)	Temperature input: -1999 to +9999 °C[°F] or -199.9 to +999.9 °C [°F] Voltage/current inputs: -span to +span	Sensor correction is made by adding bias value to measured value (PV).	0 or 0.0
LCK	Set data lock function (LCK)	See *5.	Performs set data change enable/disable.	0000

NOTE

Some parameter symbols may not be displayed depending on the specification.

***1: Precautions for heater break alarm (HBA) setting**

- Displayed only for when HBA is selected as second alarm.
- HBA is not available on a current output.
- Set HBA set value to a value about 85 % of current transformer input value (CT). However, when power supply variations are large, set the HBA to a slightly smaller value. In addition, when two or more heaters are connected in parallel, set the HBA to a slightly larger value so that it is activated even with only one heater is broken (However, within the value of CT).
- When the HBA set value is set to "0.0" or the current transformer is not connected, the HBA is turned on.

***2: Precautions for control loop break alarm (LBA) setting**

- Displayed only for when LBA is selected as first alarm or second alarm.
- Usually set the set value of the LBA to a value twice the integral time (I).
- No control loop break alarm can be used at heat/cool PID control action.
- No LBA function is activated while the AT function is activated.
- The LBA function is activated only at the 0 % or 100 % of PID computed value. Therefore, the time from trouble occurrence till the activation of the LBA function equals the time until the PID computed value becomes 0 % or 100 % plus the LBA setting time.
- If LBA setting time is too short or does not match the controlled object, the LBA may be turned on and off or not be turned on. In this case, depending on the situation, change the LBA setting time.

*3: Relay contact output : 20 sec, Voltage pulse output/Trigger output for triac driving/Triac output : 2 sec

*4: Relay contact output : 20 sec, Voltage pulse output/Triac output : 2 sec

***5: Details of set data lock level selection**

Setting	Details of lock level	Setting	Details of lock level
0000	SV and parameter can be set.	0011	Only SV can be set.
0001	Only SV and alarms (ALM1, ALM2) can be set.	0101	Only alarms (ALM1, ALM2) can be set.
0010	Only setting items other than alarms (ALM1, ALM2) can be set.	0110	Only setting items other than SV and alarms (ALM1, ALM2) can be set.
0100	Only setting items other than SV can be set.	0111	SV and parameter cannot be set.

- Each locked setting item can only be monitored.
- Each alarm setting item [HBA, LBA, LBD] can be locked when any of "0001," "0011," "0101" and "0111" is set.

5.3 Parameter setting procedure



Key operational cautions

- Even if the displayed value is changed, it is not registered. To register it, press the **SET** key.
- If the key is not operated for more than 1 minute, the present mode returns to the PV/SV display mode.

Setting set value (SV)

Example: Following is an example of set value (SV) to 200 °C

(1) Set to the SV setting mode



Press the **SET** key to enter the SV setting mode. The digit which light brightly is settable.

(2) Shift of the digit brightly lit

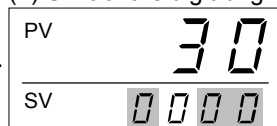

Press the **<R/S** key to shift the digit which lights brightly up to the hundreds digit.

(3) Numeric value change

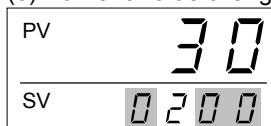

Press the **UP** key to set "2." Pressing the **UP** key increase numerals, and pressing the **DOWN** key decrease numerals.

(4) Set value entry

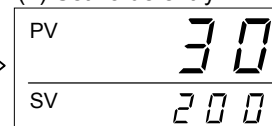

After finishing the setting, press the **SET** key. All of the set value digits light brightly and as a result the instrument returns to the PV/SV display mode.

Setting parameters other than set value (SV)

The setting procedures are the same as those of example (2) to (4) in the above "Setting set value (SV)." Pressing the **SET** key after the setting end shifts to the next parameter. When no parameter setting is required, return the instrument to the PV/SV display mode.

6. OPERATIONS

6.1 Operation procedures

CAUTIONS

- Connect the input signal wiring, and then turn on the power. If the input signal wiring opens, the instrument judges the input is disconnected.
 - Upscale ^{*1} : TC input , RTD input (Downscale when the input is shorted.)
 - Downscale ^{*1} : TC input (To be specified when ordering), Voltage input (Current input) ^{*2}
 - *1 : Alarm output ON (However, for the W or A control action type, the control output on both heat-side and cool-side is turned off.)
 - *2 : For 0 to 5 V DC or 0 to 20 mA DC, both control and alarm outputs are indefinite.
- No influence is exerted upon the instrument for power failure of 20 ms or less. For power failure of more than 20 ms , the instrument performs the same operation as that at the time of power on after power recovery (This applies only when alarm action is turned off).
- The alarm hold action is activated when not only the power is turned on, but also the SV is changed.

- (1) Prior to starting operation, check that the mounting and wiring have been finished, and that the SV and various parameters have been set.
- (2) As this instrument does not have a power supply switch, it is ready to operate as soon as the power is turned on. Prior to factory shipment, the instrument is set to "RUN (operation start)."

NOTES

- If the instrument is switched to operation stop (STOP), its display, output, etc. become as follows.
 - Display: The PV display unit shows $STOP$ (STOP).
 - Output: Control output OFF, Alarm output OFF
 - Suspended when the AT function is activated. (The PID constants are not updated.)
 - Stopped when the ST function is activated. (Re-started in RUN mode.)
- This instrument holds the conditions that exist just before the power is turned on. For example, if the power is turned off in STOP mode, the instrument starts in STOP mode when the power is turned on again.

6.2 Set data lock (LCK) function

The set data lock function is used to prevent misoperation by not setting any parameter which is not used frequently. The parameter thus locked cannot be set or changed, but can only be monitored.

6.3 Autotuning (AT) function

The AT function automatically measures, computes and sets the optimum PID and LBA constants. This function is activated after-ON, during temperature rise and/or when control is stabilized from any process state.

■ Requirements for AT start

Start AT when all the following conditions are satisfied:

- Prior to starting the AT function, end all the parameter settings other than PID and LBA.
- Confirm the LCK function has not been engaged.

■ Requirements for AT suspension

The AT function is suspended if any of the following conditions is established:

- When the SV is changed.
- When the PV bias value is changed.
- When the RUN/STOP function is changed to the "STOP."
- When the PV becomes abnormal. (According to the burnout.)
- When the power is turned on.
- When a power failure longer than 20 ms occurs.
- When the AT function does not end in about 9 hours after tuning started.

NOTES

- If the AT suspension condition is established, the AT function is immediately suspended to be changed to PID control. The PID and LBA constants at this time are the same as before starting AT. In addition, even if the AT is completed, it is automatically transferred to PID control.
- If any problems arise due to hunting exists in the control system, do not use the AT function. In this case, set each value to match the controlled object.

6.4 Self-tuning (ST) function

The ST function is used to automatically calculate and set adaptive PID constants anytime when the power is turned on; the SV is changed or the control system becomes oscillatory as the characteristic of the controlled system varies.

CAUTIONS

- **In a controlled system in which ripples may be contained by the application of periodic disturbances, use this instrument with the ST function turned off.**
- **When the power is turned on or the SV is changed with the ST function turned on, turn on the power of the controlled system (heater, etc.) before or just when the power of this instrument is turned on.**

■ Requirements for ST start

Start ST when all the following conditions is satisfied: The instrument should be in PID control. (P≠0, I≠0, D≠0 and ARW≠0.)

■ Requirements for ST stop

The ST function is stopped if any of the following conditions is established:

- When PV is out of the input range (When the instrument is overscaled or downscaled)
- When the ST function is set to the OFF state.
- When the AT function is activated. ^{*1}
- When the RUN/STOP function is changed to the "STOP." ^{*2}
- When the power is turned off.

^{*1}: If the AT function is activated, the ST function is set to the stop state. After the AT function is stopped, the ST function re-starts from the stop state.

^{*2}: If the operation state is changed from the "RUN" to "STOP," the ST function is set to the stop state. If the operation state is changed from the "STOP" to "RUN," the ST function re-starts from the stop state.

NOTES

- When control action is in heat/cool PID action, the ST function is not activated.
- The PID and ARW settings cannot be changed while the ST function is being activated. However, they can only be monitored.

7. DISPLAY AT ERROR OCCURRENCE

Error display

Err	RAM failure (Incorrect set data write, etc.)	Please contact us or your nearest RKC agent.
------------	---	--

Overscale and Underscale

Measured value (PV) (Flashing)	Measured value (PV) exceeds the input range.	WARNING In order to prevent electric shock, prior to replacing the sensor, always turn off the power. Sensor or input lead check.
	Overscale Measured value (PV) exceeds the high input display range limit.	
	Underscale Measured value (PV) exceeds the low input display range limit.	

8. INPUT RANGE TABLE

Input type	Model code	Input type	Model code	Input type	Model code	Input type	Model code	Input type	Model code					
K	0 to 200 °C	K' 01	J	0 to 800 °F	J' A1	N	0 to 1200 °C	N' 01	U	*2 -199.9 to +100.0 °C	U' 02	Pt100	-100.0 to +100.0 °F	D' A4
	0 to 400 °C	K' 02		0 to 1600 °F	J' A2		0 to 1300 °C	N' 02		0.0 to 400.0 °C	U' 03		-100.0 to +300.0 °F	D' A5
	0 to 600 °C	K' 03		0 to 2192 °F	J' A3		0 to 2300 °F	N' A1		*2 -199.9 to +999.9 °F	U' A1		0.0 to 100.0 °F	D' A6
	0 to 800 °C	K' 04		0 to 400 °F	J' A6		0 to 2372 °F	N' A2		*2 -100.0 to +200.0 °F	U' A2		0.0 to 200.0 °F	D' A7
	0 to 1000 °C	K' 05		0 to 300 °F	J' A7		*2 -199.9 to +400.0 °C	T' 01		0.0 to 999.9 °F	U' A3		0.0 to 400.0 °F	D' A8
	0 to 1200 °C	K' 06		*1 0 to 1600 °C	R' 01	*2 -199.9 to +100.0 °C	T' 02	0 to 400 °C		L' 01	0.0 to 500.0 °F		D' A9	
	0 to 1372 °C	K' 07		*1 0 to 1769 °C	R' 02	-100.0 to +200.0 °C	T' 03	0 to 800 °C		L' 02	-199.9 to +649.0 °C		P' 01	
	0 to 100 °C	K' 13	*1 0 to 1350 °C	R' 04	0.0 to 350.0 °C	T' 04	0 to 800 °F	L' A1		-199.9 to +200.0 °C	P' 02			
	0 to 300 °C	K' 14	*1 0 to 3200 °F	R' A1	*2 -199.9 to +752.0 °F	T' A1	0 to 1600 °F	L' A2		-100.0 to +50.0 °C	P' 03			
	0 to 450 °C	K' 17	*1 0 to 3216 °F	R' A2	*2 -100.0 to +200.0 °F	T' A2	-199.9 to +649.0 °C	D' 01		-100.0 to +100.0 °C	P' 04			
	0 to 500 °C	K' 20	*1 0 to 1600 °C	S' 01	*2 -100.0 to +400.0 °F	T' A3	-199.9 to +200.0 °C	D' 02		-100.0 to +200.0 °C	P' 05			
	0 to 800 °F	K' A1	*1 0 to 1769 °C	S' 02	0.0 to 450.0 °F	T' A4	-100.0 to +50.0 °C	D' 03		0.0 to 50.0 °C	P' 06			
	0 to 1600 °F	K' A2	*1 0 to 3200 °F	S' A1	0.0 to 752.0 °F	T' A5	-100.0 to +100.0 °C	D' 04		0.0 to 100.0 °C	P' 07			
	0 to 2502 °F	K' A3	*1 0 to 3216 °F	S' A2	0 to 2000 °C	W' 01	-100.0 to +200.0 °C	D' 05		0.0 to 200.0 °C	P' 08			
20 to 70 °F	K' A9	400 to 1800 °C	B' 01	0 to 2320 °C	W' 02	0.0 to 50.0 °C	D' 06	0.0 to 300.0 °C	P' 09					
J	0 to 200 °C	J' 01	*1 0 to 1820 °C	B' 02	0 to 4000 °F	W' A1	0.0 to 100.0 °C	D' 07	0.0 to 500.0 °C	P' 10				
	0 to 400 °C	J' 02	800 to 3200 °F	B' A1	0 to 1300 °C	A' 01	0.0 to 200.0 °C	D' 08	0 to 5 V DC	4' 01				
	0 to 600 °C	J' 03	*1 0 to 3308 °F	B' A2	0 to 1390 °C	A' 02	0.0 to 300.0 °C	D' 09	0 to 10 V DC **	0.0 to 5' 01				
	0 to 800 °C	J' 04	0 to 800 °C	E' 01	0 to 1200 °C	A' 03	0.0 to 500.0 °C	D' 10	1 to 5 V DC	to 6' 01				
	0 to 1000 °C	J' 05	0 to 1000 °C	E' 02	0 to 2400 °F	A' A1	-199.9 to +999.9 °F	D' A1	0 to 20 mA DC	100.0 to 7' 01				
	0 to 1200 °C	J' 06	0 to 1600 °F	E' A1	0 to 2534 °F	A' A2	-199.9 to +400.0 °F	D' A2	4 to 20 mA DC	8' 01				
0 to 450 °C	J' 10	0 to 1832 °F	E' A2	U *2 -199.9 to +600.0 °C	U' 01	-199.9 to +200.0 °F	D' A3							

*1 0 to 399°C/0 to 799°F : Accuracy is not guaranteed.
 *3 This input type can not be selected in the Z-1021 specification.

*2 -199.9 to -100.0°C / -199.9 to -158.0°F : Accuracy is not guaranteed.

**Z-1010 specification

9. HOW TO PULL OUT THE INTERNAL ASSEMBLY

! WARNING

- To prevent electric shock or instrument failure, only qualified personnel should be allowed to pull out the internal assembly.
- To prevent electric shock or instrument failure, always turn off the power before pulling out the internal assembly.
- To prevent injury or instrument failure, do not touch the internal printed circuit board.

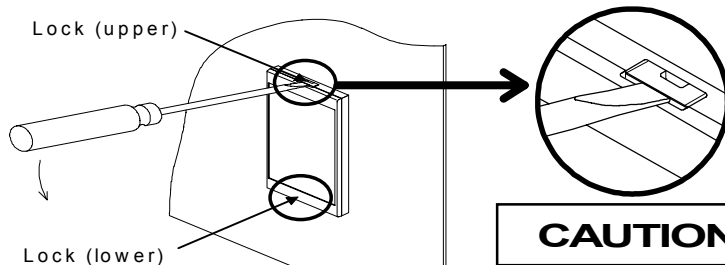

Unlock using such a screwdriver. Gently press down on handle for the upper lock and lift up for the lower lock.

CAUTION

Don't force to unlock to protect the frame against possible damage.

NOTES

- Unlocking points (marked with "O") depend on the model as follows:

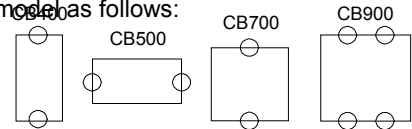

- Recommended tool: Minus-headed screwdriver (Recommended head width: 6mm or less)

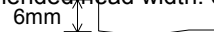

To conform to IEC1010 requirements, this instrument has been designed so that the internal assembly can be pulled out by using an appropriate tool for protection from an electric shock.